



MID SIZE SERIES Rough Terrain SCISSOR LIFTS

The Mid-Size Series Rough Terrain Scissor Lifts combine solid and powerful design elements to meet the demands of the most challenging job site environment. All models are equipped with Skyjack's unique axle based 4WD system which features a "No Spin" rear differential and limited slip front differential for unmatched terrainability.

Working heights for these two models are 10,2 m (SJ 7127) and 12,7 m (SJ 7135), while capacities are 680 kg (SJ 7127) and 454 kg (SJ 7135) respectively.

A standard 1,4 m roll out extension deck adds to the already generous platform sizes, giving a combined 6,97 sq m of platform space. Both models are drivable at full height, and feature 30% gradeability.

Consistent with Skyjack's robust and reliable design features, the Mid Size Series Rough Terrain Scissor Lifts utilize Skyjack's standard colour coded and numbered wiring system with analog based controls.

MID-SIZE SERIES

Rough Terrain Scissor Lifts

Specifications	SJ 7127	SJ 7135
A Work Height	10,2 m	12,7 m
B Raised Platform Height	8,2 m	10,7 m
C Lowered Platform Height	1,5 m	1,7 m
D Overall Width	1,8 m	1,8 m
E Overall Length	3,3 m	3,3 m
F Stowed Height (Rails Up)	2,7 m	2,9 m
G Stowed Height (Rails Down)	2,0 m	2,1 m
H Platform Width (Inside Dimension)	1,6 m	1,6 m
I Platform Length (Inside Dimension)	3,0 m	3,0 m
Deck Extension	1,4 m	1,4 m
Ground Clearance	0,2 m	0,2 m
Wheelbase	2,4 m	2,4 m
Weight	4000 kg	4287 kg
Gradeability	30%	30%
Turning Radius (Inside)	2,8 m	2,8 m
Turning Radius (Outside)	5,3 m	5,3 m
Lift Time (With Rated Load)	43 sec	41 sec
Drive Speed (Stowed)	4,8 km/h	4,8 km/h
Drive Speed (Raised)	0,5 km/h	0,5 km/h
Maximum Drive Height	Full Height	Full Height
Capacity (Overall)	681 kg	454 kg
Maximum # of Persons	5	4

STANDARD FEATURES

- Drivable at full height
- Axle based 4WD
- "No Spin" rear differential and limited slip front differential
- Disc brake system on rear axle
- 1,4 m roll out extension deck
- 29hp Kubota Diesel engine on roll out tray
- Analog control system
- Colour coded and numbered wiring system
- 30% Gradeability
- Grip lug, foam-filled tyres
- Wiring for AC outlet on platform
- Tilt alarm with drive & lift cut-out
- Overload sensing system
- Lowering warning system
- Flashing light
- Operator horn
- Hinged railing system
- Full height spring hinged gate at rear
- Lanyard attachment points
- Scissor guards
- Tie down/lift lugs

OPTIONS†

- 1,4 m powered extension deck
- Diesel scrubber
- Independent/auto leveling outriggers
- Shop airline to platform
- 3.5kW hydraulic generator
- Non-marking grip lug foam-filled tyres
- All motion audible alarm

† Capacities, and machine weights may differ when options are added

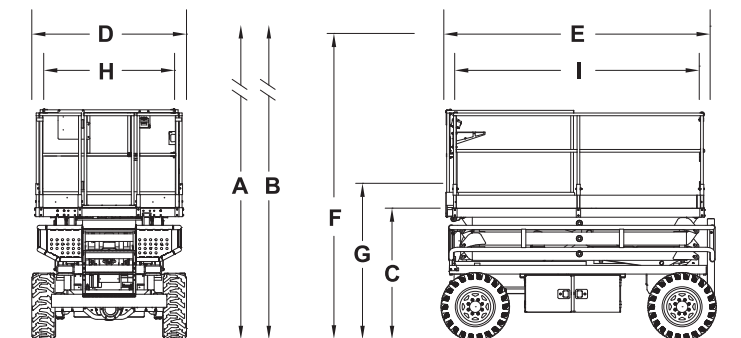

Head Office
Westside, London Road,
Hickstead, West Sussex,
RH17 5LZ

T 01444 88 11 88
F 01444 88 11 99
E hiredesk@facelift.co.uk
W facelift.co.uk

facelift
access and safety made easy