

Range P

Cod. PRP1358

**Description:** Articulated/Telescopic platform, fully hydraulic with high specifications of strength, reliability and easy maintenance. Specifically designed to fulfill the high standard of quality requested by professional users, ensuring a long working life and a high residual value.

## Performances

Working height mt.		26.20
Max load in the basket kg.	† †   †	200
Max working outreach mt.	† †   †	12.70
Turret rotation °		Continuous
Hose track		Internal
Controls in the basket		Hydraulic multifunctions joystick

## Platform specifications

Steel basket dimensions mt.	1.60x0.75
Fiberglass basket dimensions mt.	1.40x0.70
Basket rotation °	45 + 45
Front outriggers	Inclined
Back outriggers	Inclined
Foot plate gauge min. mt.	3.00



## Assembling

This assembly represents the "multipurpose" version with outriggers slightly outside the vehicle mirrors width. The excellent capacity of levelling allows however high performances and operational possibilities.

**Body** Purposely designed assembly to optimize functionality and utilization

**Standards** CE certificate

**Accessories** There are available a wide range of accessories, many of them are already included as stand machine. It is recommended to contact our sales network for more information.

**Other types of assembling and different vehicles** We are in position to propose the same machine with different type of assembly and / or on different types of vehicles. Contact our sales organization to obtain information about all the possible solutions that we are able to offer.

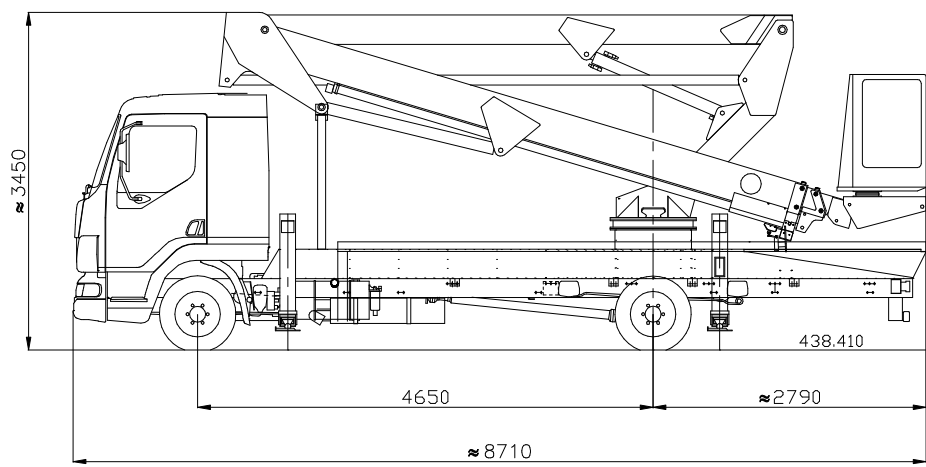
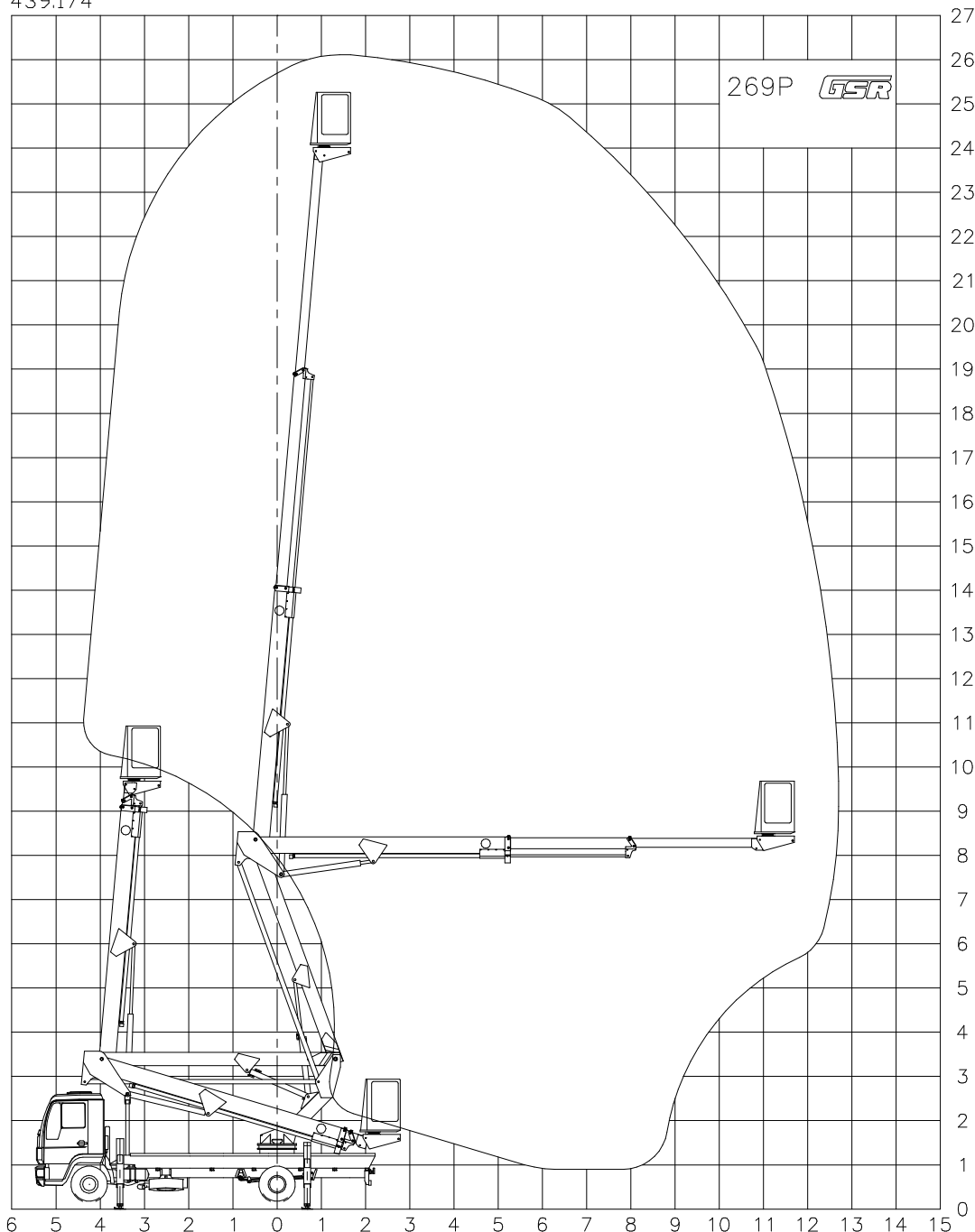

APPROXIMATE DATA - TECHNISCHE ANDERUNGEN VORBEHALTEN  
 DONNEES INDICATIVES - DATI INDICATIVI

AGGIORNAMENTI MODIFICHE

C H  
 B G  
 A F

SAFE WORKING LOAD	 = 200 KG
NENNTRAGFAHIGKEIT IM KORB	
CHARGE NOMINALE DANS LE PANIER	
PORTATA NOMINALE IN NAVICELLA	



DENOMINAZIONE  
**269P Basic**  
 DAF FA LF45 - 7.5 T

DATA 19-03-2003  
 CODICE PRP1358