



## **Rough Terrain Self-Propelled Scissor Lift**

**GS-4390 RT  
GS-5390 RT**

- Ready to tackle the most rigorous sites with superior gradeability and traction-controlled four-wheel drive.



**Genie Industries**

# GS-4390 RT GS-5390 RT

## GS-4390 RT and GS-5390 RT

- Large platform with durable diamond-plate aluminium flooring. Both the single 1.93m (76 in) multi-position slide-out extension deck on the front of the machine and the second 1.63m (64 in) slide out extension deck on the rear of the machine come as standard.
- Rear platform railing can be removed for easier loading and unloading of materials.
- Slide-out engine tray allows easy access to components.
- Automatic leveling hydraulic outriggers are standard

### Standard Features

- GS-4390 has 15.1m (49ft) working height and GS5390RT has 18.2m (59ft) working height.
- 680 kg (1,500 lb) load capacity
- 7.30 m platform
- Automatic levelling hydraulic outriggers
- Positive traction-controlled four-wheel drive
- 50% gradeability
- Proportional drive
- Two-speed lift functions
- Troubleshooting diagnostics
- Two self-closing entry gates
- Foam-filled tyres
- AC wiring to platform
- Descent alarm
- Tilt sensor with an audible alarm
- Horn
- Hour meter



### Options and Accessories

- Motion alarm
- Dual flashing beacons
- Propane tank kit (single and/or additional)
- Hydraulic oil cooler
- 3,500 watt generator (110 volt/50 hz)
- Ford LRG 425 EFI Petrol/LPG 82hp (61kw) engine

### Standard Compliance

- CE EN280

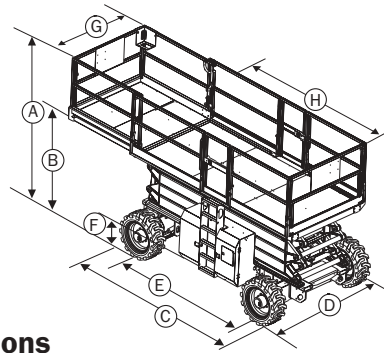

### Specifications

Model	GS-4390 RT		GS-5390 RT	
	Metric	US	Metric	US
Working height <sup>1</sup>	15.1 m	49 ft	18.2 m	59 ft
Platform height	13.1 m	43 ft	16.2 m	53 ft
(A) Height – stowed				
guardrails	2.93 m	115 ½ in	3.15 m	124 in
guardrails lowered	2.25 m	88 ¾ in	2.47 m	97 ¾ in
(B) Height – stowed (platform)	1.80 m	71 in	2.02 m	79 ½ in
(C) Length – stowed				
w/double deck extension	3.98 m	156 ½ in	n/a	n/a
(D) Width	2.29 m	90 in	2.29 m	90 in
(E) Wheelbase	2.92 m	115 in	2.92 m	115 in
(F) Ground clearance	36 cm	14 in	36 cm	14 in
(G) Platform width	1.83 m	72 in	1.83 m	72 in
(H) Platform length				
super deck extended	7.38m	290.15in	7.38m	290.5in
Slide-out deck extension(s)				
standard front deck	1.93 m	76 in	1.93 m	76 in
rear deck	1.63 m	64 in	1.63 m	64 in
Lift capacity	680 kg	1,500 lb	680 kg	1,500 lb
Extension deck capacity (max)	227 kg	500 lb	227 kg	500 lb
Turning radius – outside	5.33 m	210 in	5.33 m	210 in
Turning radius – inside	2.16 m	85 in	2.16 m	85 in
Power source	Deutz Diesel 56 hp (42 kw)			
Auxiliary power unit	12V DC	12V DC	12V DC	12V DC
Drive speed – stowed	8.0 km/h	5 mph	8.0 km/h	5 mph
Drive speed – raised	1.1 km/h	0.7 mph	1.1 km/h	0.7 mph
Raise/lower speed	45 sec/39 sec		55 sec / 49 sec	
Self-leveling capability w/ outriggers				
- side/side	12°		12°	
- front/rear	7°		7°	
Controls	Two-speed lift and proportional drive			
Tyres	12-21.5 NHS foam filled			
Gradeability (4x4)	50%		50%	
Drive	four wheel			
Multiple disc brakes	dual rear wheel			
Fuel tank capacity	114 litre	30 gal	114 litre	30 gal
Hydraulic tank capacity	114 litre	30 gal	114 litre	30 gal
Weight <sup>2</sup>	7,323 kg	16,145 lb	7,888 kg	17,390 lb

<sup>1</sup>The metric equivalent of working height adds 2 m to platform height. Imperial adds 6 ft to platform height  
<sup>2</sup>Weights are subject to change