



# Self-Propelled Articulating Boom

Z™-45/25 & Z™-45J/25J  
DC and Bi-Energy

Efficient electric  
or Bi-Energy power  
for all day use.



# Make short work of big jobs.

With an extended reach, models with jibs, and a variety of outstanding performance features, the Z-45/25 DC/Bi-Energy handles the most challenging high-reach jobs. The revolutionary Genie Bi-Energy system combines the quiet, emission-free and efficient operation of a 48V DC machine with the versatility of a diesel generator powered machine to provide a boom that is ideal for indoor and outdoor applications.

# articulating

## Quick and Maneuverable

The Z-45/25's enhanced design helps get you where you need to go, quickly and easily. The new 5 ft (1.52 m) inside turning radius delivers excellent maneuverability. Z-45/25J models with a 5 ft (1.52 m) articulating jib boom are also available to provide a 135° range of motion.

## Unsurpassed Speed and Gradeability

This 4x2 is the fastest boom in its class. Travels 3 mph (4.8 km/h) with 30% gradeability.

## Dual Parallelogram Riser

Advanced design allows ascent and descent along a vertical plane with or without retraction or extension of the boom.

## Large Platform with Hydraulic Rotation

The standard 6 ft (1.83 m) all-steel platform lifts up to 500 lb (227 kg). Dimensions of 30 x 72 in (76 cm x 1.83 m) allow ample space for two workers and their tools. Platform features a 180° hydraulic rotation for Z-45/25 models and a 160° hydraulic rotation for Z-45/25J models. Also includes automatic platform leveling with a manual hydraulic override system and an AC power outlet.

## Ground Controls

Located at eye level with easy to understand controls and including auxiliary power, key switch, emergency stop, hour meter and all boom functions.

## Safety in Sight

All instructional and safety decals are straightforward and conveniently located to be clearly visible.

## Drive Enable System

Informs operator when the drive and steer functions will move opposite controller movements.





### Power for the Long Haul

The Bi-Energy always operates with the all new, Sep-Ex 48V DC drive system and has the added feature of an on-board diesel powered generator. The generator acts as a 100 amp battery charger to provide enough electrical power to operate all boom functions even when the batteries are fully discharged.

The Kubota Z482, 12 hp, water cooled, 2-cylinder, diesel powered generator package will charge a fully discharged machine in only 3.5 hours.

The Kubota Z482 diesel will operate for approximately 17 hours before refueling is necessary.

The direct electric, 48V drive system provides outstanding battery life when not using the engine generator.

An on-board 25 amp AC charger is standard to provide a means for overnight charging.

### Reach

The 51 ft (15.8 m) working height, outreach of over 24 ft (7.3 m) – for both the Z-45/25 and Z-45/25J models – and up and over clearance of over 22 ft (6.7 m) lets you reach higher and farther than ever before.

### Increased Strength

Larger, stiffer primary boom and extension tubes offer increased strength and durability. Improved cable track includes box tube support combined with a wider plastic track.

### Fewer Parts Overall

Commonality among all Z-45/25 models results in fewer service requirements.

### Maintenance Made Easy

The Bi-Energy component tray swings out 90° for complete accessibility during routine maintenance and repairs.





## Standard Features

- Over 51 ft (15.8 m) working height
- Over 24 ft (7.3 m) horizontal reach
- Up and over clearance of over 22 ft (6.7 m)
- 5 ft (1.52 m) turning radius
- 500 lb (227 kg) lift capacity
- Fully proportional controls
- Hydraulic platform rotation
- 24V DC auxiliary power unit
- Drive enable system
- End mount platform on Z-45/25J models

- AC wiring to platform
- Tilt alarm
- Horn
- Hour meter
- Industrial air tires

## Options and Accessories

- Alarm package
- Platform swing gate
- Air line to platform
- Full rail platform pinch guard
- Platform work light
- Platform control box cover
- Foam filled and non-marking tire packages

## Standards Compliance

- ANSI/SIA A92.5
- CSA CAN3-B354.4-M82
- CE compliance option
- AS 1418.10

## Range of Motion

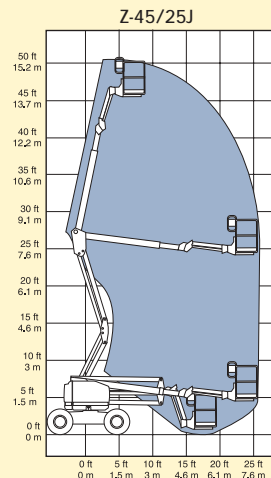
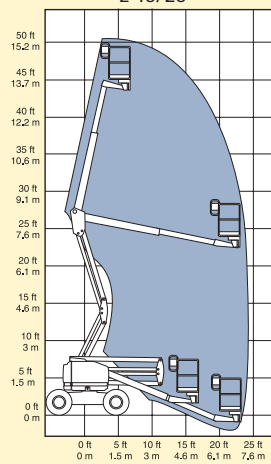

## Z-45/25

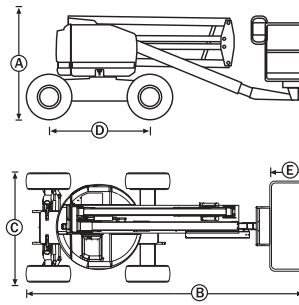

## Z-45/25J

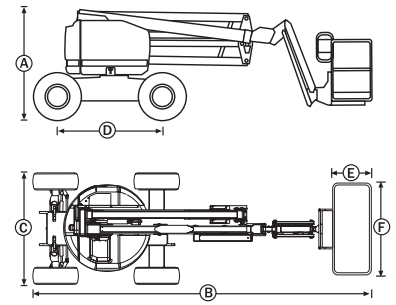

## Specifications

Model	Z-45/25		Z-45/25J	
	US	Metric	US	Metric
Working height*	51 ft 5 in	15.8 m	51 ft 3 in	15.8 m
Platform height	45 ft 5 in	13.8 m	45 ft 3 in	13.8 m
(A) Height - stowed	6 ft 7 in	2 m	6 ft 7 in	2 m
(B) Length - stowed	18 ft	5.5 m	22 ft 3 in	6.8 m
(C) Width	5 ft 9 in	1.75 m	5 ft 9 in	1.75 m
(D) Wheelbase	6 ft 8 in	2.03 m	6 ft 8 in	2.03 m
Ground clearance - center	8 1/2 in	22 cm	8 1/2 in	22 cm
Ground clearance - min	7 in	18 cm	7 in	18 cm
(E) Platform length	30 in	76 cm	30 in	76 cm
(F) Platform width	72 in	1.83 m	72 in	1.83 m
Horizontal reach max	24 ft 6 in	7.5 m	25 ft 3 in	7.7 m
Up and over clearance	22 ft 6 in	6.9 m	22 ft 6 in	6.9 m
Lift capacity	500 lb	227 kg	500 lb	227 kg
Turning radius - inside	5 ft	1.52 m	5 ft	1.52 m
Turntable rotation	359° non-continuous		359° non-continuous	
Turntable tailswing	zero		zero	
Platform rotation	180°		160°	
Power source	48V DC (8 6V 315 AH batteries) or 48V DC with Kubota Diesel 12 hp (9 kw)			
Drive speed - stowed	3 mph	4.8 km/hr	3 mph	4.8 km/hr
Drive speed - raised	0.6 mph	1 km/hr	0.6 mph	1 km/hr
Lift speed to full height	90 sec		90 sec	
Controls	24V DC proportional		24V DC proportional	
Auxiliary power unit	24V DC		24V DC	
Tires	9 - 14.5		9 - 14.5	
Gradeability - stowed	30%		30%	
Hydraulic tank capacity	8 gal	30 litre	8 gal	30 litre
Fuel tank capacity	9 gal	34 litre	9 gal	34 litre
Weight - DC**	15,900 lb	7,214 kg	16,100 lb	7,305 kg
Weight - Bi-Energy**	16,100 lb	7,305 kg	16,300 lb	7,396 kg

\* The metric equivalent of working height adds 2 m to platform height. U.S. adds 6 ft to platform height.  
\*\* Weight will vary depending on options and/or country standards.