

COMPACT[®] 8/10/12 DX

Rough-terrain Scissor Lifts

- Compact and manoeuvrable.
- Increased Workspace area.
- Excellent gradeability (40%).
- Full proportional controls.
- Optimised safety.
- Robust, reliable and easy to maintain design.



ISO 9001
GROUP
PINGUET
HAULOTTE



ARTICULATED BOOMS



VERTICAL MASTS



TELESCOPIC BOOMS



SCISSOR LIFTS



TRAILERS

Haulotte[®]

ON THE UP

COMPACT[®] 8/10/12 DX

STANDARD FEATURES

- Deutz engine
- 4 wheel drive et 2 front steering wheels
- Hydraulic differential lock
- 3° Tilt alarm
- One 1.2m (47 in) platform extension
- 12V - 70 Ah Batteries
- Removable operator's control box
- Free wheeling device
- Hourmeter
- Towing hooks / lifting eyes
- Hydraulic brakes
- Manual emergency lowering pull
- Foam filled all terrain tyres
- Side protections
- Horn
- Load limiter in cage with beep
- Removable control box
- Hooks for safety harness
- Driving proportional controls

OPTIONS AND ACCESSORIES

- Individual levelling outriggers
- Rotating beacon
- Power line in cage
- Fall down handrails
- Automatic levelling outriggers
- Motion alarm
- Working light
- Catalytic exhaust
- Biodegradable oil
- Warning kit for engine oil



ROUGH-TERRAIN SCISSOR LIFTS

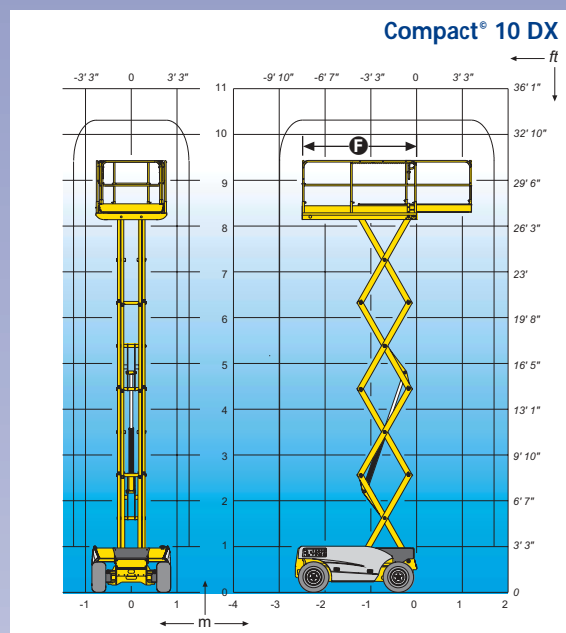
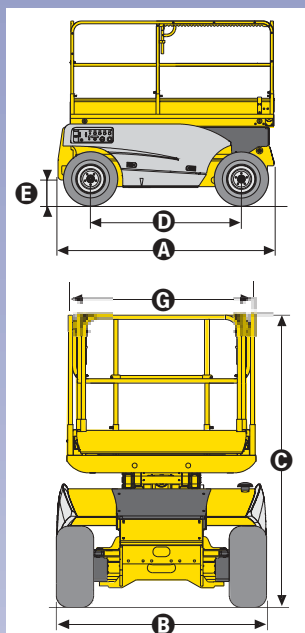

AS1418.10

SPECIFICATIONS

	Compact [®] 8 DX		Compact [®] 10 DX		Compact [®] 12 DX	
Working height	28,4 m	7 ft 6 in	10,2 m	33 ft 5 in	12,14 m	40 ft
Platform height	6,4 m	21 ft	8,2 m	27 ft	10,14 m	33 ft 3 in
Platform capacity	565 kg - 1,245 lb					
A Length	2,65 m - 8 ft 7 in					
B Width	1,80 m - 6 ft					
C Stowed height (guardrail)	2,3 m	7 ft 5 in	2,37 m	7 ft 10 in	2,54 m	8 ft 4 in
Stowed height (platform)	1,2 m	4 ft	1,3 m	4 ft 2 in	1,4 m	4 ft 6 in
D Wheelbase	1,87 m - 6 ft 1 in					
E Ground clearance	25 cm - 10 in					
F x G Platform size	2,5 x 1,54 m - 8 ft 2 in x 5 ft 1 in					
Platform extension	1,2 m - 47 in					
Drive speed	0,8 / 5,5 km/h - 0,5 / 3,4 mph					
Outside turning radius	3,73 m - 12 ft 3 in					
Inside turning radius	1,21 m - 4 ft					
Lift / lower speed (s)	30 / 35 sec.		35 / 40 sec.		40 / 45 sec.	
Power source	Deutz 17,9 kw					
Gradeability	40%					
Brakes	Hydraulic					
Tyres (foam filled)	26 x 12-12					
Hydraulic tank	80 l - 17,6 gal					
Fuel tank	30 l - 6,60 gal					
Weight	3 120 kg	6878 lb	3 330 kg	7341 lb	3 830 kg	8443 lb

