

# ROUGH-TERRAIN SCISSOR LIFTS



**H 12 SX**  
**H 15 SX**  
**H 18 SX**



- 20 ft x 6 ft (6 m x 1.8 m) platform.\*
- 1.980 lb (900 kg) lift capacity.
- 45% gradeability.
- Standard 4 wheel drive.

\* with twin extension decks.

ISO 9001  
GROUP  
PINGUELY  
HAULOTTE



ARTICULATED BOOMS    VERTICAL MASTS    TELESCOPIC BOOMS    SCISSOR LIFTS    TRAILERS

**Haulotte®**

ON THE UP

**H 12 SX**  
**H 15 SX**  
**H 18 SX**

# Rough-terrain scissor lifts

## The Haulotte® advantages

- Double extension for increased working area
- Hydraulic differential lock for improved rough terrain capability
- 35 cm / 14 in ground clearance ensures exceptional rough terrain performance
- Tight turning radius ensuring an excellent manoeuvrability
- Maximum drive speed : 6 km/h / 3,7 mph
- Stowed height and width making transport and manoeuvrability easier
- Foam filled tyres
- Full proportional controls
- Load limiter in cage
- Robust, reliable and easy to maintain design

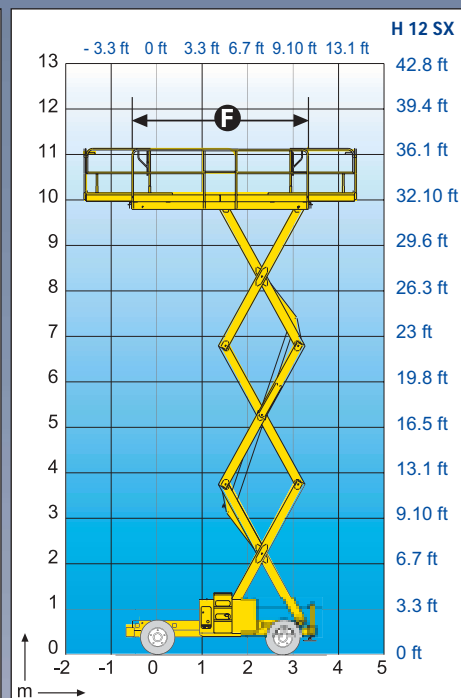
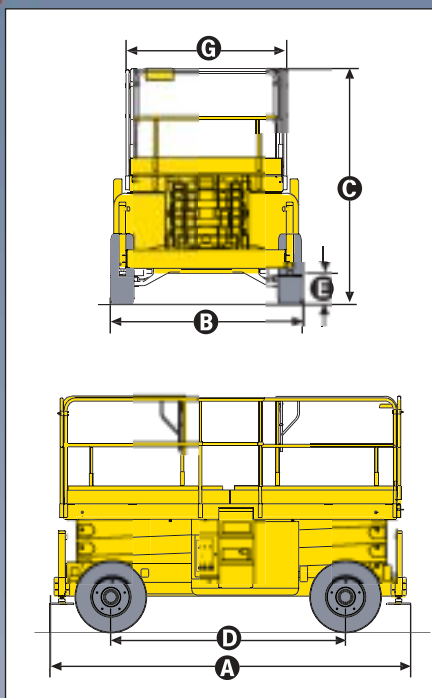

## STANDARD FEATURES

- Hatz "silent pack" diesel engine
- 4 wheel drive (2 front steering wheels)
- Tilt alarm
- 1 m / 3 ft 3 in double extension
- Load limiter in cage
- 12 V - 95 Ah batteries
- 14 V - 50 A alternator
- Removable operator's control box
- Free wheeling device
- Hourmeter
- Horn
- Towing hooks
- Hydraulic brakes
- Hydraulic stabilisers
- Manual emergency lowering system

## OPTIONS & ACCESSORIES

- Catalytic exhaust
- Rotating beacon
- Travel alarm
- Extra wide tyres
- Power outlet on platform
- Working light
- Encoded starting device
- Biodegradable hydraulic oil

## SPECIFICATIONS

	H 12 SX		H 15 SX		H 18 SX	
Working Height	39ft	12 m	49ft	15 m	59ft	18 m
Platform Height	33ft	10 m	43ft	13 m	53ft	16 m
Platform Capacity (one extension)	1,980 lb	900 kg	1,540 lb	700 kg	1,320 lb	600 kg
Maximum Capacity (two extensions)	1,540 lb	700 kg	1,100 lb	500 kg	1,100 lb	500 kg
<b>A</b> Length	13 ft 6 in / 4.12 m					
<b>B</b> Width	7 ft 5 in / 2.25 m					
<b>C</b> Stowed Height	8 ft 5 in	2.57 m	9 ft	2.75 m	9 ft 8 in	2.96 m
Travel/transport Height	5 ft 7 in	1.71 m	6 ft 3 in	1.90 m	6 ft 11 in	2.11 m
<b>D</b> Wheelbase	9 ft / 2.75 m					
<b>E</b> Ground clearance	14 in / 35 cm					
<b>F</b> x <b>G</b> Platform size	13 ft 1 in x 6 ft 2 in / 4 x 1.89 m					
Platform extension	3 ft 3 in / 1 m					
Extension capacity	440 lb / 200 kg					
Drive speed	1 / 3.7 mph / 1.6 / 6 km/h					
Outside turning radius	16 ft 3 in / 4.96 m					
Raise / Lower speed	43 / 65 sec.		46 / 57sec.		60 / 60 sec.	
Power source	Diesel 32 hp - 24 kW / Diesel 32CV - 24 kW					
Gradeability	45%					
Tilt alarm	5°		5°		3°	
Tyres (Foam Filled)	10 x 16.5"					
Hydraulic tank	22 gallons - 100 l					
Fuel tank	14 gallons - 65 l					
Weight	11,770 lb	5,350 kg	13,546 lb	6,180 kg	16,060 lb	7,300 kg



AS1418.10

