

# HA16PE

## Articulating boom

- Bi-energy (fuel / electric).
- +70° / -70° fly jib.
- 550 lb (250 kg) platform capacity.
- 30 ft (9.1 m) horizontal outreach.
- 6 ft (1.83 m) width.



ARTICULATED BOOMS



VERTICAL MASTS



TELESCOPIC BOOMS



SCISSOR LIFTS



TRAILERS

**Haulotte®**

ON THE UP

# HA16PE

## ARTICULATING BOOM

### The Haulotte® advantages

- Improved working area through a positive / negative articulating fly jib with 140° movement
- Bi-energy (fuel / electric) allows both inside and outside uses
- Hydraulic differential lock and 10 in (26.5cm) ground clearance for improved rough terrain capability
- Full proportional controls and simultaneous boom functions improve productivity
- Continuous 360° turntable rotation
- Zero tailswing
- 180° hydraulic platform rotation
- Compact travel/transport dimensions
- Robust, reliable and easy to maintain design

### STANDARD FEATURES

- 2 wheel drive and 4 wheel steer
- Hydraulic brakes
- 45 amp 48 V battery charger
- Load limiter in cage
- 220 V/16 A power line to cage
- 5° tilt alarm
- 12 V Battery / electrical control system
- Emergency hand pump
- Free wheeling device
- Hourmeter
- Slewing block pin
- Towing hooks / lifting eyes

### OPTIONS & ACCESSORIES

- Travel / motion alarm
- Rotating beacon
- Working light
- Catalytic exhaust

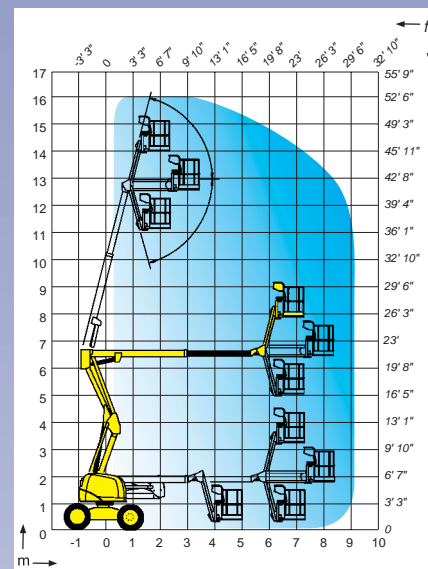
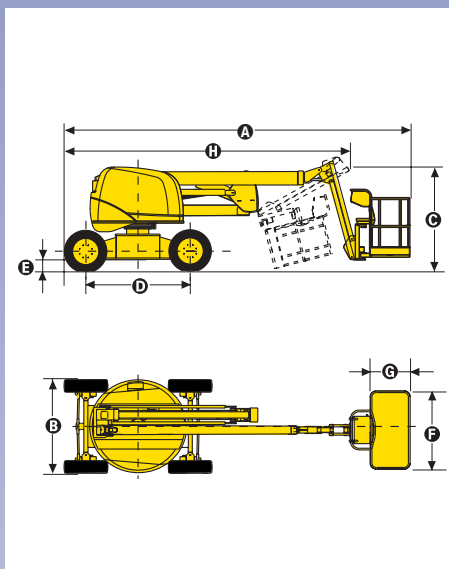

### SPECIFICATIONS

Working height	52 ft	16.0 m
Platform height	46 ft	14.0 m
Horizontal outreach	30 ft	9.1 m
Up and over clearance	21 ft 4 in	6.5 m
Platform capacity	550 lb	250 kg
Fly jib range of motion	140° (+70° / -70°)	
<b>A</b> Length	21 ft 8 in	6.65 m
<b>B</b> Width	6 ft	1.83 m
<b>C</b> Stowed height	7 ft 2 in	2.2 m
<b>D</b> Wheelbase	6 ft 6 in	2.0 m
<b>E</b> Ground clearance	10 in	26.5 cm
<b>F</b> x <b>G</b> Platform size	59 in x 32 in	1.50 m x 0.8 m
<b>H</b> Travel/transport length	18 ft	5.50 m
Tailswing	0	0
Drive speed	0.9 / 3.7 mph	1.5 / 6 km/h
Outside turning radius	11 ft 5 in	3.47 m
Turntable rotation - continuous	360°	360°
Hydraulic platform rotation	180°	180°
Engine	Diesel Deutz 38 hp - 28 kw	
Batteries	48V (6 x 8V 375 AH)	
Gradeability	25%	25%
Tyres (Foam Filled)	245/80 - R 19.5	
Hydraulic tank	26 gallons	100 l
Fuel tank	14 gallons	65 l
Weight	17.382 lb	7.885 kg

AS1418.10

