

## STAR 11 STAR 12



- Compact: 360° rotation with zero tailswing.
- 8 ft 2 in (2.5 m) outreach.
- 463 lb (210 kg) platform capacity.
- Proportional electric controls.
- High operating autonomy (9 hours).

ISO 9001  
GROUP  
PINGUELY  
HAULOTTE



ARTICULATED BOOMS



VERTICAL MASTS



TELESCOPIC BOOMS



SCISSOR LIFTS



TRAILERS

**Haulotte**®

ON THE UP

# STAR 11 STAR 12

# Vertical masts

## The Haulotte® Advantages

- Full electric drive
- Narrow turning radius for excellent manoeuvrability in the most congested areas
- 140° (+70°/-70°) fly Jib for better accessibility
- 32 in (0.80 m) platform extension increasing working surface
- Maximum drive speed: 5 km/h (3.1 mph)
- Gradeability up to 25%
- Driveable at full height
- Robust, reliable and easy to maintain design

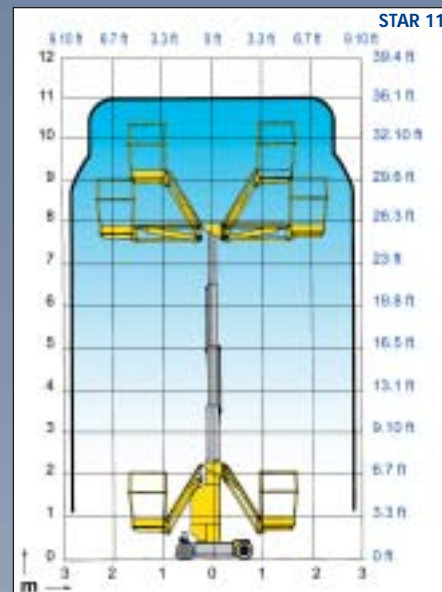
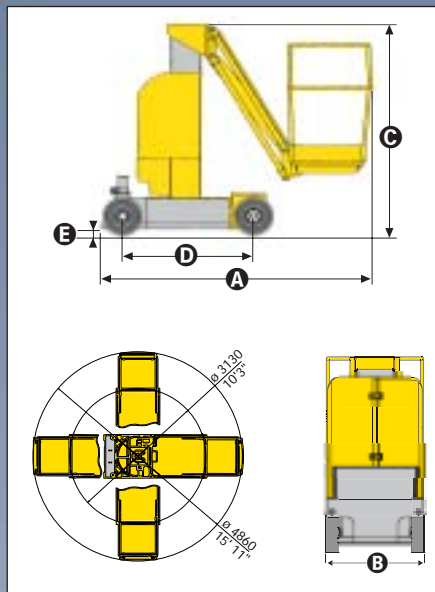

## STANDARD FEATURES

- 24V electric engine
- 24 V - 275 AH traction batteries
- 30 amp battery charger
- Battery charging indicator
- 3° tilt alarm
- 2 drive speeds
- 2 wheel drive and steer
- Free wheeling device
- Hour counter
- Horn in basket
- 2 emergency stops
- 2 control boxes
- Removable control box in basket

## OPTIONS & ACCESSORIES

- Non-marking tyres
- Centralised filling
- Flashing light
- Motion alarm
- 220 V socket in basket
- Airline to cage

## SPECIFICATIONS

	STAR 11		STAR 12	
Working height	11 m	36 ft	12 m	39 ft 4 in
Platform height	9 m	30 ft	10 m	33 ft
Horizontal reach	2.5 m / 8 ft 2 in			
Platform capacity	210 kg / 463 lb, 2 people			
<b>A</b> Length	2.35 m / 7 ft 7 in			
<b>B</b> Overall width	1.02 m	3 ft 3 in	1.25 m	4 ft 1 in
<b>C</b> Stowed height	2.20 m	7 ft 2 in	2.40 m	7 ft 9 in
<b>D</b> Wheelbase	1.20 m / 4 ft			
<b>E</b> Ground clearance	8 cm / 3 ft 1 in			
Platform dimensions	0.96 x 0.96 m - 38 x 26 in			
Tailswing	0			
Drive speed	1.1/5 km/h - 0.7/3.1 mph			
Raise speed (sec.)	31		32	
Outside turning radius	2 m	6 ft 6 in	2.15 m	7 ft
Turnable rotation	360°			
Batteries	24 V - 275 AH			
Autonomy	9 hours			
Built-in-charger	30 A			
Maximum gradeability	25%			
Tilt alarm	3°			
Solid tyres	318/114 - 203.2			
Total weight	2,470 kg	5,445 lb	2,450 kg	5,400 lb

