

STAR 8 STAR 10



- 9 ft 10 in (3,1 m) outreach.
- Compact: 360°. Rotation with zero tail swing.
- 507 lb (230 kg) platform capacity.
- Proportional electric controls.
- High autonomy.



The Haulotte® advantages

- Full electric drive with the ability to drive at full height
- Proportional controls provide for smooth and progressive movements
- Narrow turning radius for better accessibility
- Increased safety with 3° slope sensor and pot hole protection
- The positive/negative jib offers more flexibility throughout the working envelope
- 2.8 mph (4.5 km/h) travel speed
- 25% gradeability
- Low total weight for easier transport and greater accessibility
- Ergonomic and spacious cage design
- Robust, reliable and easy to maintain

STANDARD FEATURES

- 24 V Electric motor
- 24 V – 240 Ah traction batteries
- 30 Amp battery charger
- Battery charge indicator
- 3° tilt alarm
- 2 drive speed
- 2 wheel drive
- Non marking tyres
- Brake release system
- Hourmeter
- Horn in cage
- Emergency stop buttons at cage and ground
- 2 Control stations, cage and ground
- Moveable cage control panel

OPTIONS & ACCESSORIES

- Centralised battery filling
- Flashing beacon
- Safety harness anchor points
- Motion alarm
- 220V line to cage
- Airline to cage

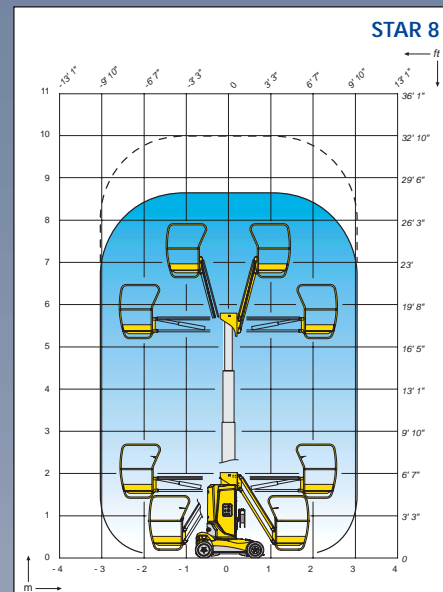
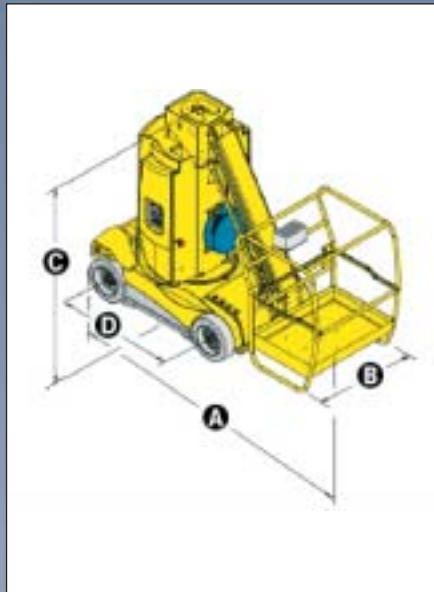

SPECIFICATIONS

	Star 8		Star 10	
Working Height	8.73 m	28 ft 7 in	10 m	32 ft 10 in
Platform Height	6.73 m	22 ft 1 in	8 m	26 ft 3 in
Horizontal outreach	3,1 m	10 ft 2 in	3,1 m	10 ft 2 in
Platform Capacity	200 kg	441 lb	230 kg	507 lb
A Length	2.61 m	8 ft 7 in	2.61 m	8 ft 7 in
B Width	0.99 m	3 ft 3 in	0.99 m	3 ft 3 in
C Stowed Height	1.99 m	6 ft 6 in	1.99 m	6 ft 6 in
D Wheelbase	1.2 m	4 ft	1.2 m	4 ft
Ground Clearance	10 cm	4 in	10 cm	4 in
Platform size	0.97 x 0.67 m		3 ft 2 in x 2 ft 2 in	
Tailswing	0		0	
Drive speed	0,7 / 4.5 km/h		0.43 / 2.8 mph	
Outside turning radius	1.87 m		6 ft 2 in	
Turntable rotation	360°		360°	
Traction batteries	24 V / 240 Ah		12 V / 240 Ah	
Gradeability	25%		25 %	
Tilt alarm	3°		3°	
Non marking tyres	10 x 16 x 10.5		10 x 16 x 10.5	
Weight	2.480 kg	5,467 lb	2.540 kg	5,600 lb

