

ARTICULATING BOOM LIFTS



JLG 600 SERIES

- Choice of models with up to a 20 m working height
- Fast boom and drive speeds improve work productivity
- Multiple simultaneous boom functions get you to the job quicker
- Proportional controls achieve smoother movement for operator comfort
- Excellent manoeuvrability for positioning of machine and platform
- Handle the roughest of terrain with increased engine power

For more details check the JLG Technical Specification Guide or ask your local JLG representative.



Oscillating axle option for tough travel

Provides increased traction when travelling.



Controls designed for ease of operation

Easier to operate when positioning and controlling movement.



Articulating Jib

Allows for greater versatility when positioning the platform around obstacles.
*Model 600AJ only.



Low mount platform access

Step-in entry height and high strength railings provide operator both convenience and security.



Narrow Chassis Option

A reduced chassis width of 2.1 m helps access into congested work areas.



Greater serviceability

Improved access with an engine swing-out tray.

JLGEUROPE

600 SERIES ARTICULATING BOOM LIFTS

	600A	600AJ	600A narrow	600AJ narrow
Platform Height	18.29 m	18.29 m	18.29 m	18.29 m
Horizontal Outreach	12.07 m	12.12 m	12.07 m	12.12 m
Up and Over Height	8.05 m	8.05 m	8.05 m	8.05 m
Swing (Continuous)	360°	360°	360°	360°
Platform Capacity – Unrestricted	230 kg	230 kg	230 kg	230 kg
Platform Rotator (Hydraulic)	180°	180°	180°	180°
Jib – Overall Length	—	1.83 m	—	1.83 m
Jib - Range of articulation	—	135° (+70°/ -65°)	—	135° (+70°/ -65°)
A. Platform Size	0.91 m x 1.83 m	0.91 m x 1.83 m	0.91 m x 1.83 m	0.91 m x 1.83 m
B. Overall Width	2.44 m	2.44 m	2.13 m	2.13 m
C. Tailswing –working condition	Zero	Zero	0.13 m	0.13 m
D. Stowed Height	2.56 m	2.56 m	2.56 m	2.56 m
E. Stowed Length	8.05 m	8.82 m	8.05 m	8.82 m
F. Wheelbase	2.44 m	2.44 m	2.44 m	2.44 m
G. Ground Clearance	0.30 m	0.30 m	0.30 m	0.30 m
Gross Vehicle Weight*	10,330 kg	10,650 kg	9,616 kg	10,183 kg
Maximum Ground Bearing Pressure	4.93 kg/cm ²	4.86 kg/cm ²	6.42 kg/cm ²	6.50 kg/cm ²
Drive Speed 2WD	5.6 km/h	5.6 km/h	5.6 km/h	5.6 km/h
Drive Speed 4WD	6.4 km/h	6.4 km/h	—	—
Gradeability 2WD	30%	30%	30%	30%
Gradeability 4WD	45%	45%	—	—
Tyres	14 x 17,5 Foam Filled	14 x 17,5 Foam Filled	14 x 17,5 Solid, Segmented	14 x 17,5 Solid, Segmented
Axle Oscillation (optional)	0.20 m	0.20 m	0.20 m	0.20 m
Turning Radius – Inside 2WS	3.48 m	3.48 m	3.71 m	3.71 m
Turning Radius – Inside 4WS	1.67 m	1.67 m	1.70 m	1.70 m
Turning Radius – Outside 2WS	5.38 m	5.38 m	5.03 m	5.03 m
Turning Radius – Outside 4WS	3.55 m	3.55 m	3.40 m	3.40 m
Diesel Engine – Deutz F4M1011E	48.5 kW	48.5 kW	48.5 kW	48.5 kW
Fuel Tank Capacity	113.6 L	113.6 L	113.6 L	113.6 L
Hydraulic Reservoir	115.8 L	115.8 L	115.8 L	115.8 L
Auxiliary Power	12V DC	12V DC	12V DC	12V DC

*Certain options or country standards will increase weight.

Specifications may change to meet country standards or with the addition of optional equipment.

JLG MODEL 600A

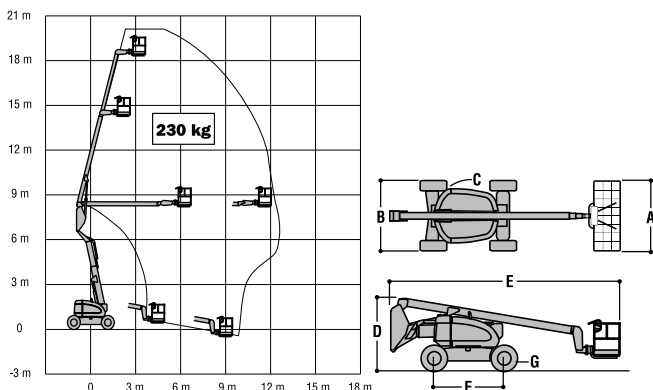

JLG MODEL 600AJ

