



Omme lift

Specialist lightweight,
narrow, rough terrain
telescopic platforms

R - Series
- mounted on crawlers



SAFE ACCESS - made of steel

Type RD and RBD are identical apart from the power sources. Standard features include hydraulic stabilizers, proportional controls and turnable basket.

Type RD is powered by a diesel engine and is especially suited for outdoor use.

Type RBD is a battery/diesel bi-energy unit. This type is therefore suited for both indoor and outdoor use.

The specially designed high and broad profiles of the steel booms allow greater outreach whilst maintaining a high degree of stability and rigidity.

All guards are manufactured of robust aluminium and steel plates.

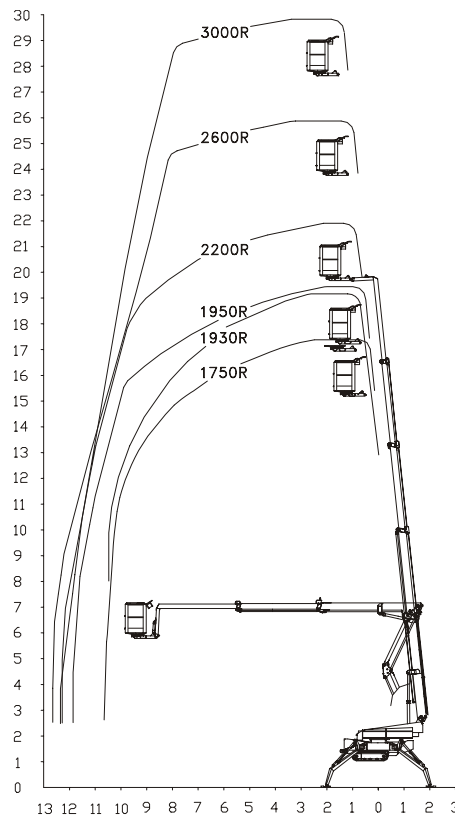

The crawler platforms are well suited for cleaning and general maintenance in narrow places or high atriums.

All control boxes are fitted with emergency stops.

Battery power is used for indoor operation to avoid fume and noise pollution.

To increase the battery capacity even further, the RBD-lifts can be fitted with a 230V mains transformer which can provide almost continuous battery operation.

The battery pack allows substantially more drive power than standard 230V mains. The gradeability on battery power is no less than up to 30% (16.7°).



The basket mounting forms a "fly" boom on the end of the outer telescope which increases the up and over outreach considerably.



The long jib significantly enhances the up and over facility and adds approx. 1.40 m to the working height.



The 1250 cm² stabilizer pads reduce the point loading to maximum 25kN. The sliding hinged pads with PVC-plates avoid surface scratching during set up.



A transport width of only 1.10 m and a height of less than 2 m allow entry through most doorways and arches.



The average force from the tracks is down to only 27 N/cm². The low force and the non-marking belts give optimal protection of the surface.



The compact dimensions allow access in narrow and awkward areas.



The telescopic boom enables the required working height to be achieved quickly and safely.



The combination of an articulating riser and a telescopic boom gives easy access up and over obstacles.



A gradeability up to 40% (21.8°) and a transport width of only 1.10 m reflect a high degree of manoeuvrability and user friendliness.



Optionally the lifts can be supplied with adjustable track width, hydraulically retractable from 1.50 m to 1.10 m.



The specially designed stabilizers provide quick and easy set up on slopes of up to 40% (21.8°).



The tilt alarm sounds before the maximum incline is reached. Place the stabilizers in the wide position if there are any doubts regarding the gradeability.



The operational width can be reduced by adjusting the stabilizer spread according to the required working envelope.

Technical data:	1930 RD	1930 RBD	1750 RD	1750 RBD	1950 RD	1950 RBD	2200 RD	2200 RBD	2600 RD	2600 RBD	3000 RD	3000 RBD
Lift type	Scissor/Telescope		Telescope		Telescope		Telescope		Telescope		Telescope	
Max. working height, m	19.1 m		17.2 m		19.3 m		21.8 m		25.6 m		29.7 m	
Max. outreach, m	10.2 m		10.4 m		11.7 m		12.2 m		12.6 m		12.6 m	
Max. basket load, kg	200 kg		200 kg		200 kg		200 kg		200 kg		200 kg	
Rotation	± 400°		± 400°		± 400°		± 400°		± 400°		± 400°	
Basket size, m	1.25x0.8x1.1m		1.25x0.8x1.1m		1.25x0.8x1.1m		1.25x0.8x1.1m		1.25x0.8x1.1m		1.25x0.8x1.1m	
Turnable basket	± 41°		± 41°		± 41°		± 41°		± 41°		± 41°	
Battery	24V/200Ah/5h		24V/200Ah/5h		24V/200Ah/5h		24V/200Ah/5h		24V/200Ah/5h		24V/200Ah/5h	
Charger	24 V/30 A		24 V/30 A		24 V/30 A		24 V/30 A		24 V/30 A		24 V/30 A	
Transformer	O		O		O		O		O		O	
Diesel engine	14 kW/18.8 hp	14 kW/18.8 hp	14 kW/18.8 hp	14 kW/18.8 hp	14 kW/18.8 hp	14 kW/18.8 hp	14 kW/18.8 hp	14 kW/18.8 hp	14 kW/18.8 hp	14 kW/18.8 hp	14 kW/18.8 hp	14 kW/18.8 hp
Generator	24 V/22 A	24 V/22 A	24 V/22 A	24 V/22 A	24 V/22 A	24 V/22 A	24 V/22 A	24 V/22 A	24 V/22 A	24 V/22 A	24 V/22 A	24 V/22 A
Transport length	5.90 m		5.80 m		6.30 m		6.40 m		7.20 m		8.00 m	
Transport height	2.07 m		1.99 m		1.99 m		1.99 m		1.99 m		1.99 m	
Transport width	1.10 m		1.10 m		1.10 m		1.10 m		1.10 m		1.10 m	
Operational width	4.25/3.45 m		4.25/3.45 m		4.25/3.45 m		4.25/3.45 m		4.25/3.45 m		4.25/3.45 m	
Total weight	3150 kg	3250 kg	2800 kg	2900 kg	2880 kg	3000 kg	3000 kg	3050 kg	3500 kg	3625 kg	3650 kg	3775 kg
Gradeability	19.3° (35%)		21.8° (40%)		21.8° (40%)		21.8° (40%)		19.3° (35%)		19.3° (35%)	
Deployment ability	21.8° (40%)		21.8° (40%)		21.8° (40%)		21.8° (40%)		21.8° (40%)		21.8° (40%)	
Crawler track length	1.42 m		1.42 m		1.42 m		1.42 m		1.74 m		1.74 m	
Number of supporting rollers	3		3		3		3		4		4	
Hydraulic stabilizers	+		+		+		+		+		+	
Proportional controls	+		+		+		+		+		+	
Hydraulic propulsion	+		+		+		+		+		+	
230 V outlet in basket	+		+		+		+		+		+	
Jib-movable	÷		÷		÷		O		O		O	
Wireless remote control, propulsion	O		O		O		O		O		O	
White tracks	O		O		O		O		O		O	

+ Standard O Optional ÷ Not available



Drive operation: Standard via wired remote control.
Optional wireless control.



Transport on a purpose built trailer.
Up to type 2200, the total weight is less than 3500 kg.



Transport on a small truck without a ramp.



Transport on a truck with a ramp.



Lifting eyes are fitted.