

Specifications

MODELS	GRC™-12	
MEASUREMENTS	US	Metric
Working height*	18 ft	5.66 m
Platform height	12 ft	3.66 m
A B Platform dimensions (length x width)		
Ext Platform dimensions - retracted	38 x 29.5 in	.97 x .75 m
Ext Platform dimensions - extended	55 x 29.5 in	1.4 x .75 m
C Height - stowed	67 in	1.70 m
D Length - stowed	4 ft 5.75 in	1.37 m
E Width - ANSI, CSA	2 ft 5.5 in	.75 m
CE, AUS	2 ft 7.5 in	.80 m
F Ground clearance - center	2.5 in	.06 m

PRODUCTIVITY		
Lift capacity	500 lbs	227 kg
Lift capacity - extension deck	250 lbs	113 kg
Drive speed - stowed	2.5 mph	4.0 km/h
Drive speed - raised	0.5 mph	0.8 km/h
Gradeability**	30%	
Turning radius - inside	zero	zero
- outside	4 ft 7 in	1.42 m
Raise / lower speed	12 / 16 sec	12 / 16 sec
Controls	24V DC proportional	
Tires - solid non-marking	10 x 3 x 8 in	25 x 8 x 20 cm

POWER		
Power source	24V (four 6V 225 Ah batteries)	
Hydraulic system capacity	2.2 gal	8.33 L

WEIGHT***		
ANSI, CSA	1,916 lbs	869 kg
CE, AUS	2,090 lbs	948 kg

STANDARDS COMPLIANCE ANSI A92.6, CSA B354.2, CE Compliance, AS 1418.10

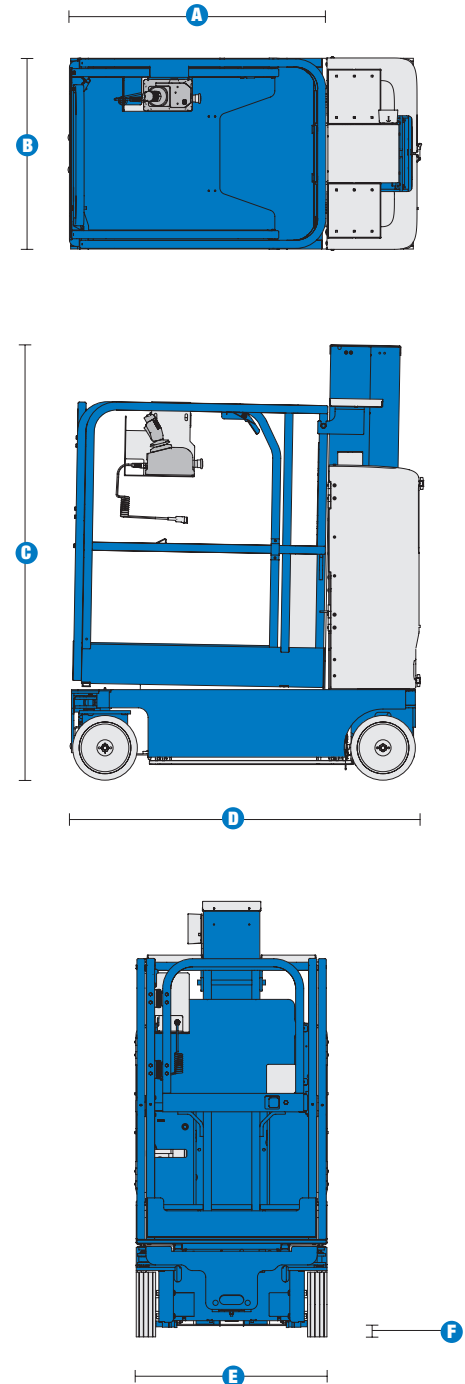

* The metric equivalent of working height adds 2 m to platform height. U.S. adds 6 ft to platform height.
 ** Gradeability applies to driving on slopes. See operator's manual for details regarding slope rating.
 *** Weight will vary depending on options and/or country standards.

Features

EASILY CONFIGURED TO MEET YOUR NEEDS

PLATFORM

- Steel platform and extension deck with swing gate

POWER

- 24V (four 6V 225 Ah batteries)

TIRE

- Non-marking solid tires

STANDARD FEATURES

MEASUREMENTS

GRC™-12

- 18 ft (5.66 m) working height
- 12 ft (3.66 m) platform height
- Up to 500 lb (227 kg) lift capacity

PRODUCTIVITY

- Steel platform and extension deck with swing gate
- Auxiliary platform lowering
- Low 15.5 in (.39 m) platform entry height
- Steel tube-in-tube mast system
- Compact base 29.5 x 53.75 in (.75 x 1.37 m)
- Ground clearance 2.5 inches (stowed)
- Fully proportional lift and drive controls
- Battery charge indicator
- Onboard diagnostic system
- AC power to platform
- Work station trays
- Descent and tilt alarm
- Zero inside turning radius
- Dual wheel brakes
- Hydraulic brake release
- Pothole protection
- Hinged rear ABS covers for easy access to all major electrical and hydraulic components
- Tie down attachment points
- Overhead crane attachment point
- Large forklift pockets access
- Non-marking solid tires

POWER

- Automatic 25 amp battery charger



OPTIONS & ACCESSORIES

PRODUCTIVITY

- Dual flashing beacons
- Motion alarm
- Fluorescent tube caddy
- Automotive horn
- Wheel covers

POWER

- 800 watt inverter (120-230V AC/50-60 Hz)
- Maintenance-free batteries

Head Office
Westside, London Road,
Hickstead, West Sussex,
RH17 5LZ

T 01444 88 11 88
F 01444 88 11 99
E hiredesk@facelift.co.uk
W facelift.co.uk

facelift
access and safety made easy