

DIMENSIONS	S2770BE	S3370BE
Max. working height	10.3m	12.1m
Max. platform height (A)	8.28m	10.1m
Platform size (stowed) (B)	2.74m x 1.65m	2.74m x 1.65m
Platform size (extended) (C)	4.0m x 1.65m	4.0m x 1.65m
Deck extension	1.2m	1.2m
Stowed width (D)	1.77m	1.77m
Stowed length (E)	3.36m	3.36m
Stowed height (F)	2.56m	2.70m
Min. height (guardrails folded)	1.75m	2.00m
Ground clearance	350mm	350mm

PERFORMANCE		
Platform capacity (SWL)	580kg	450kg
Max. drive height	8.28m	10.1m
Max. drive speed (stowed)	4.5km/h (engine) 1.78km/h (battery)	
Max. drive speed (elevated)	0.9km/h	0.35km/h
Raise/lower time	50/47 sec (engine) 65/47 sec (battery)	
Gradeability (engine)	35%	30%
Gradeability (batteries)	25%	25%
Max. outrigger levelling, front to rear	6°	6°
Max. outrigger levelling, side to side	10°	10°
Inside turning radius	2.83m	2.83m
Outside turning radius	4.60m	4.60m
Tyres	Non-marking 27 - 10.5 - poly filled	
Controls	Proportional joystick	
Drive system	4 wheel drive	4 wheel drive

POWER		
Power source	Kubota D-902 water cooled diesel 23.5hp and 4 x 6v 305Ah batteries	

WEIGHT		
Gross weight	3,100kg	3,920kg

TURNING RADIUS

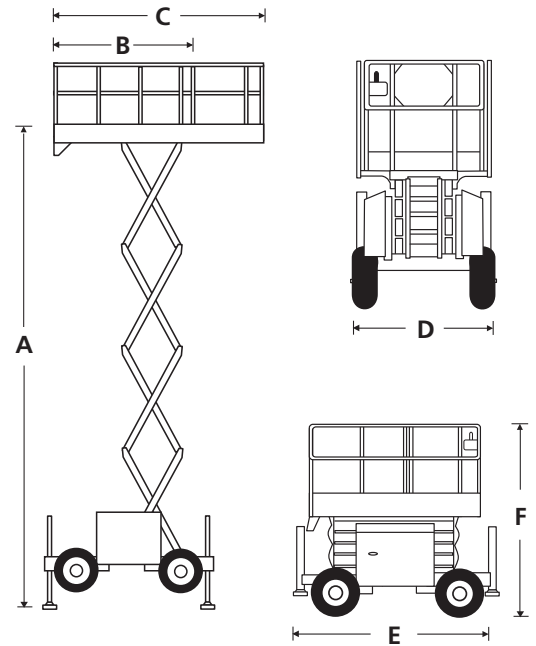
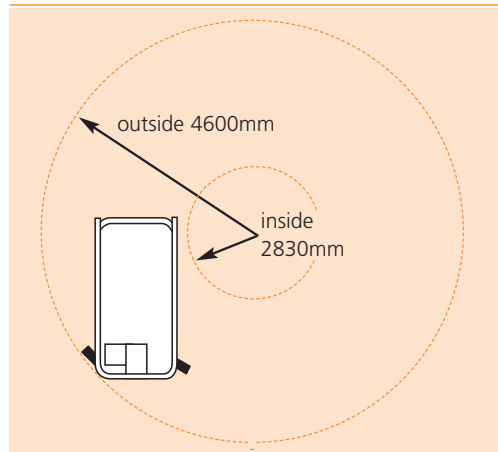

STANDARD FEATURES

- DC and diesel power - for indoor & outdoor work
- 1.2m deck extension
- 4 wheel drive
- 4 hydraulic outriggers with automatic levelling
- Proportional joystick control
- Non-marking poly filled tyres
- Articulating axle
- Driveable at full height
- Horn
- Power line to platform (no sockets)
- Drive motion alarm
- Lower warning alarm
- Fold-down guardrails
- CE approved

OPTIONS

- Special paint colours
- Environmental green oil