

DIMENSIONS	S3290RT	S4390RT	S5290RT
Max. working height	12.0m	15.0m	18.0m
Max. platform height (A)	10.0m	13.0m	16.0m
Platform size (stowed) (B)	1.83m x 4.0m		
Platform size (extended) (C)	1.83m x 6.60m		
Deck extension (each)	1.30m	1.30m	1.30m
Overall width (D)	2.27m	2.27m	2.27m
Overall length (E)	4.88m	4.88m	4.88m
Stowed height (F)	2.81m	2.98m	3.15m
Min. height (guardrails folded)	2.08m	2.25m	2.45m
Ground clearance	220mm	220mm	220mm

PERFORMANCE			
Platform capacity (SWL)	680kg	680kg	680kg
Max. drive height	9.0m	9.0m	9.0m
Max. drive speed (stowed)	6.0km/h	6.0km/h	6.0km/h
Max. drive speed (elevated)	1.1km/h	1.1km/h	1.1km/h
Raise/lower time	74/30 sec	94/77 sec	114/94 sec
Gradeability	50%	50%	40%
Max. outrigger levelling, front to rear	7°	7°	7°
Max. outrigger levelling, side to side	12°	12°	12°
Inside turning radius	2.04m	2.04m	2.04m
Outside turning radius	5.20m	5.20m	5.20m
Tyres	33 x 12.2 high grip, solid cushion		
Controls	Proportional joystick		
Drive system	4 wheel drive		

POWER	
Power source	Perkins 404D22 diesel 38kW
Auxiliary power unit	12V DC

WEIGHT			
Gross weight	7500kg	7800kg	8700kg

TURNING RADIUS

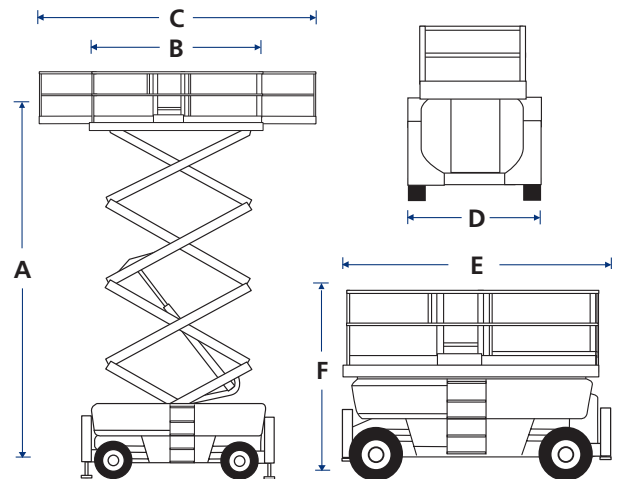
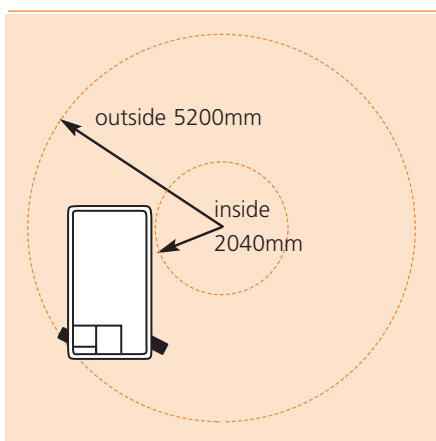

STANDARD FEATURES

- Twin manual deck extensions
- Twin self-closing platform gates
- 4 manually operated hydraulic outriggers
- Oscillating axle
- Slide-out engine tray
- Tilt alarm and cut-out
- Horn
- Hour meter
- Power line to platform (no sockets)
- DC emergency operation
- Integrated diagnostics
- Platform overload protection
- CE approved

OPTIONS

- Special paint colours
- Auto-level hydraulic outriggers
- Flashing amber beacon
- Platform work lights
- Hydraulic generator
- Hydraulic oil cooler
- Hydraulic welder
- Compressed air line to platform