

DIMENSIONS	SL26SL	SL30SL
Max. working height	10.0m	11.0m
Max. platform height (A)	8.0m	9.0m
Platform size (stowed)	1.72m x 3.66m	1.72m x 4.23m
Platform size (extended)	1.72m x 4.23m	n/a
Overall width (D)	2.13m	2.13m
Overall length (C)	3.79m	4.39m
Stowed height (B)	2.6m	2.6m
Min. height (guardrails folded)	1.1m	1.1m
Chassis ground clearance	320mm	320mm
Axle ground clearance	200mm	200mm

PERFORMANCE		
Platform capacity (SWL)	680kg	590kg
Max. drive height	8.0m	9.0m
Max. drive speed (stowed)	5.2km/h	5.2km/h
Max. drive speed (elevated)	0.8km/h	0.8km/h
Raise/lower time	21/32 seconds	24/36 seconds
Gradeability	50%	50%
Max. levelling, front to rear	9°	9°
Max. levelling, side to side	13°	13°
Inside turning radius	3.9m	3.9m
Tyres	26 x 12.00 - 12 NHS Supa Terra-Grip, poly filled	
Controls	Proportional joystick	
Drive system	4 wheel drive with hydraulic motors and flow dividers	

POWER		
Power source	Perkins diesel, water cooled engine	

WEIGHT		
Gross weight	3,085kg	3,400kg

## LEVELLING CAPABILITIES

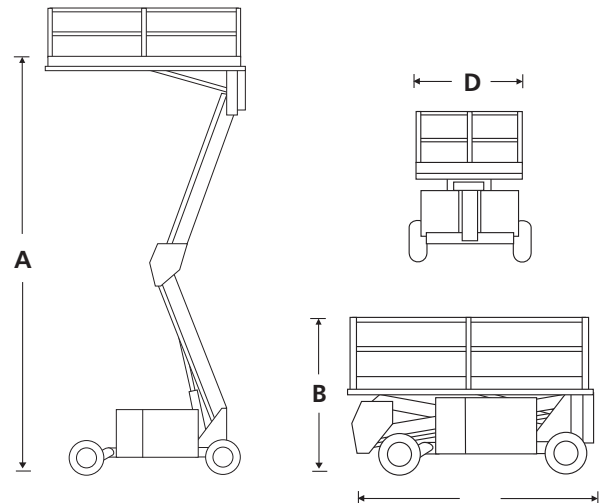
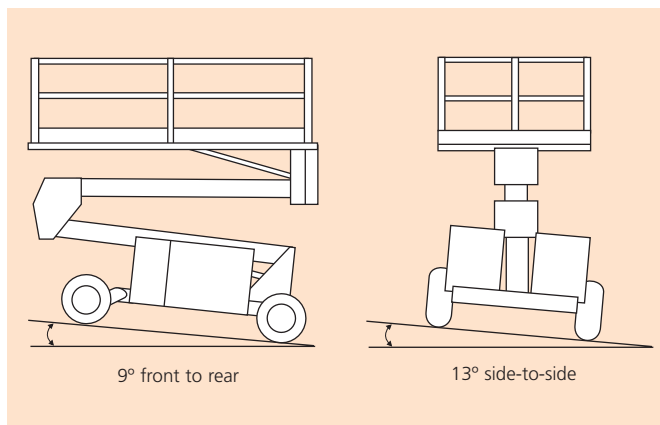

## STANDARD FEATURES

- Diesel power
- Descent alarm
- Hour meter
- Speed level - automatic powered platform levelling
- Oscillating front axle
- Poly filled high grip tyres
- Dual multi-disc brakes
- One-hand, proportional controls
- Power line to platform (no sockets)
- Fold-down guardrails
- CE approved

## OPTIONS

- Special paint colors
- All motion alarm
- Flashing amber beacon and horn
- Diesel exhaust scrubber
- Environmental green oil