

DIMENSIONS	TL49J
Max. working height	17.0m
Max. platform height	15.0m
Max. working outreach	9.1m
Platform width (C)	1.20m
Platform depth	0.80m
Outrigger footprint (A x B)	4.65m x 4.65m
Towing width (F)	1.75m
Towing length (E)	7.10m
Stowed height (D)	2.10m

PERFORMANCE	
Platform capacity (SWL)	200kg
Jib length	1.3m
Jib arc	130°
Platform rotation	160°
Turret rotation (non-continuous)	680°
Wheels	205/75R16
Controls	hydraulic proportional

POWER	
Power source	24V battery (4 x 6V 195ah batteries) or 230V mains
Power options	bi-energy (diesel/petrol and DC battery power)

WEIGHT	
Gross weight (battery model)	2250kg

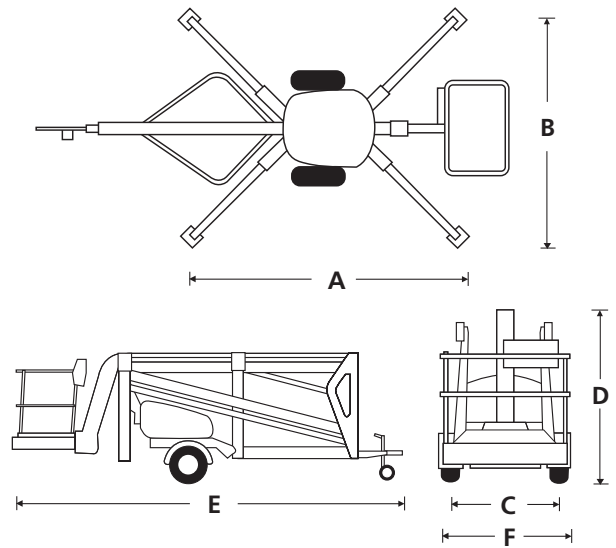

STANDARD FEATURES

- 1.3m jib with 130° working arc
- In-line boom design for maximum rigidity
- Hand pump emergency lowering from platform
- 160° powered platform rotation
- Proportional live hydraulic controls
- Power line to platform (no sockets)
- 24V battery (4 x 6V 195ah batteries) or 230V mains power
- Automatic reversing and overrun braking
- Integral road lighting board
- CE approved

OPTIONS

- Special paint colours
- Hydraulic friction drive assist system
- On-board 230V generator for mains powered units
- Bi-Energy (diesel/petrol and DC battery) power
- GRP platform

WORKING ENVELOPE

