

UpRight SL20

self propelled

narrow electric vertical lift



8.1m working height

340kg platform capacity

Roll-out deck extension
provides greater platform area
and over-reach facility

Smooth, one-hand,
proportional controls

Driveable with
platform fully elevated

Passes through
standard doorways

Non-marking tyres

Quick access to
service components

Five year structural
warranty

CE approved

| specifications | SL20 |
|-----------------------------|---|
| working height (A) | 8.10m |
| platform height (B) | 6.10m |
| platform capacity (max.) | 340kg |
| platform size (inside) | 0.74m x 2.53m |
| -with deck extended | 0.74m x 3.31m |
| weight | 1411kg |
| drive height (max.) | 6.10m |
| entry height (C) | 1.04m |
| stowed height (D) | 2.1m |
| length - deck retracted (E) | 2.75m |
| length - deck extended | 3.53m |
| width (F) | 0.84m |
| drive speed (max.) | 3.70 km/h |
| - with platform raised | 1.0 km/h |
| gradeability | 25% |
| inside turning radius | 0.64m |
| outside turning radius | 2.52m |
| ground clearance | 100mm |
| lift speed - raise/lower | 14 seconds |
| toe boards | 150mm |
| control system | one-hand proportional control |
| power source | 24V battery pack (4-220 A hour, 6V batteries) 4 HP DC electric motor |
| battery charger | 25 amp |
| non-marking tyres | 381mm diameter solid rubber, non-marking |
| parking brake | dual-spring applied, hydraulically released |

Specifications subject to change without notice. Photos and diagrams in this brochure are for promotional purposes only. Refer to appropriate UpRight Operators manual for detailed instructions on the proper use and maintenance of this equipment. The SL20 meets or exceeds all applicable CE and GS machinery directive requirements.

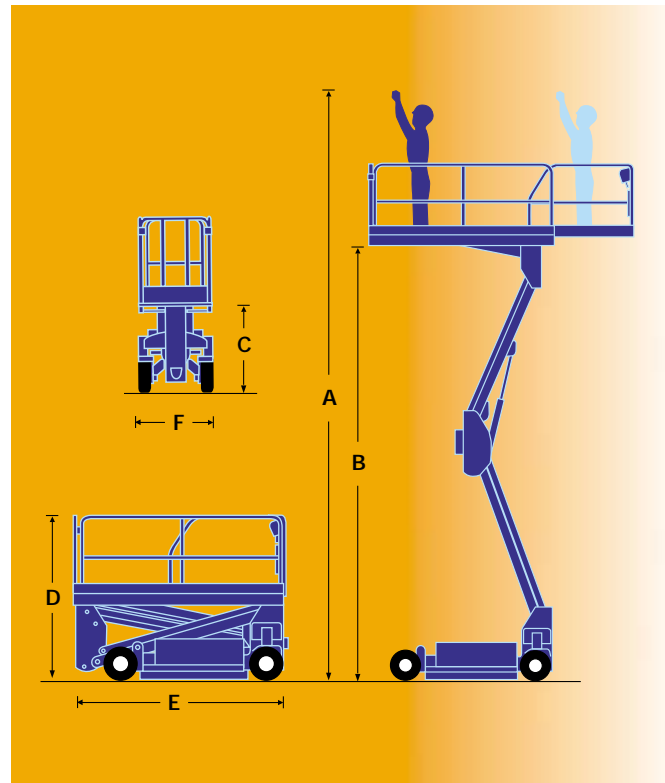

Hydraulic depression mechanism system activates when platform is elevated.



High angle steering for excellent manoeuvrability.

standard features

- Selectable motion alarm
- Dual front wheel direct drive
- Integral cushion down
- Hydraulic depression mechanism
- Crane lifting points
- Hour meter / low voltage indicator
- Heavy-duty, round guardrails
- Rear break hubs
- Tilt alarm, c/w cut out
- Overload sensor

- Horn, push button on controller
- Treaded non-marking tyres
- Platform material loading system
- Non-slip platform

options

- Power to the platform
- Flashing amber beacon
- Air line to platform
- Special paint colours
- 2/3 year warranty

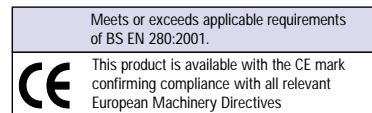

manufactured by
UpRight