



# COMPACT 8 W COMPACT 10 / 12

## Exceptional productivity

- Load capacity up to 450 kg (C8W and C10)
- Driveable at full height
- Both inside and outside use with the same load capacity
- Extended platform
- Width of 1.20 m
- Long working cycles

## Robust, reliable, easy to maintain





# COMPACT 8 W / 10 / 12



## ELECTRIC SCISSOR LIFTS

### TECHNICAL DATA

	Compact 8 W	Compact 10	Compact 12
Working height	8.27 m	10.15 m	11.98 m
Platform height	6.27 m	8.15 m	9.98 m
Driveable at full height up to	6.27 m	8.15 m	9.98 m
Lift capacity - inside	450 kg	450 kg	300 kg
Lift capacity - outside	450 kg	450 kg	300 kg
<b>A</b> Platform length - outside	2.31 m	2,31	2.31 m
<b>B</b> Platform length - extended	3.23 m	3.23 m	3.23 m
Length - extension	0.92 m	0.92 m	0.92 m
<b>C</b> Platform width - outside	1.2 m	1.2 m	1.2 m
<b>E</b> Storage height	1.28 m	1.4 m	1.53 m
<b>D</b> Height - stowed	2.14 m	2.26 m	2.39 m
<b>F</b> Overall width	1.2 m	1.2 m	1.2 m
<b>G</b> Length	2.49 m	2.49 m	2.49 m
<b>H</b> Wheelbase	1.86 m	1.86 m	1.86 m
<b>I</b> Ground clearance - Center	13 cm	13 cm	13 cm
Ground clearance - Pothole guards deployed	2.5 cm	2.5 cm	2.5 cm
Drive speed	0,8 - 3.2 km/h	0,8 - 2.9 km/h	0.8 - 2.9 km/h
Gradeability	23 %	23 %	23 %
Tilt	2 °	2 °	2 °
Lift / lower speed	35 s / 44 s	32 s / 42 s	58 s / 52 s
Turning radius - outside	2.5 m	2.5 m	2.5 m
Non-marking tires	15x5	15x5	15x5
Batteries	24 V - 340 Ah (C20)	24 V - 340 Ah (C20)	24 V - 340 Amph (C20)
Hydraulic system capacity	25 l	25 l	27 l
Weight	2 030 kg	2 330 kg	2 470 kg

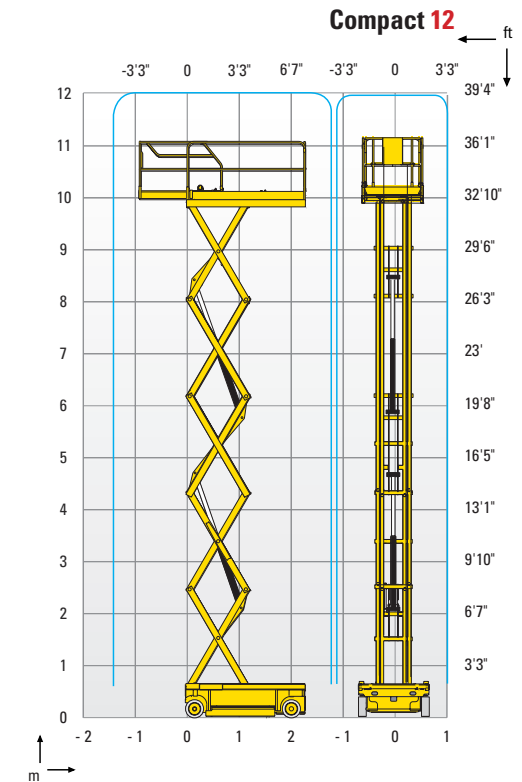
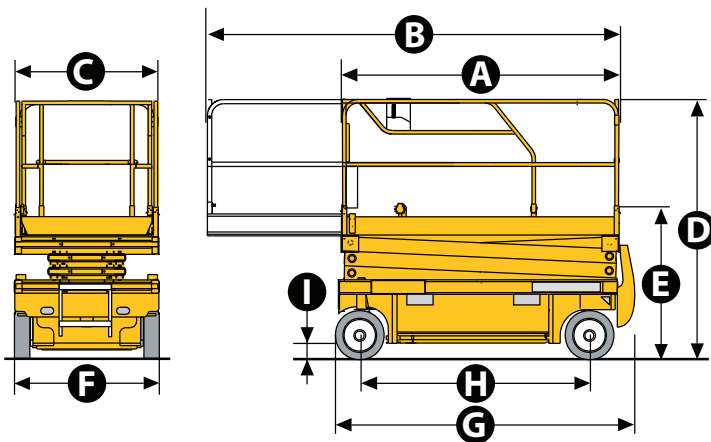

### STANDARD EQUIPMENT

- Pothole guards
- Battery charge indicator
- Proportional lift and drive
- Removable control box in platform
- Swing out component tray
- Battery charger with automatic stop
- Solid non-marking tyres
- Free wheeling device
- Tilt controller
- Load Management System in the platform
- Manual platform lowering valve
- Integrated forklift pockets
- Towing hooks
- Horn
- Hourmeter

### OPTIONS AND ACCESSORIES

- Flashing light
- Travel alarm
- Working light
- Power to platform
- Biodegradable hydraulic oil
- Folding guardrails
- Maintenance-free batteries
- Traction batteries
- Centralised battery filling

**Head Office**  
Westside, London Road,  
Hickstead, West Sussex,  
RH17 5LZ

T 01444 88 11 88  
F 01444 88 11 99  
E hiredesk@facelift.co.uk  
W facelift.co.uk

**facelift**  
access and safety made easy