



The basket is available in 2 designs:
 An angular boom with a fixed basket in a narrow or wide version.
 Perfect for indoor jobs. Can be positioned almost anywhere, and reaches easily across fixed production equipment, etc.



The Junior can be compressed with great ease. Equipped with a detachable basket (standard), it can be used almost anywhere. Owing to its low weight and compact design, the Junior can be manoeuvred with ease either outdoors or indoors.

Easy and swift set up with hydraulic support legs. Outrigger control function is standard equipment on all DENKA lifts.

The smallest of them all, but designed with a stroke of genius!

Junior is so small that it reaches everywhere, even through narrow doors. The set up is uncomplicated and needs only minimum space. Although set up can be done in less than 5 minutes, the lift offers optimum safety.

Double lifting bars give the boom great stability and make it easy to control.

The basket can be loaded with max. 120 kg in the entire working height area, max. 12 metres. The basket is available in two designs.

All DENKA LIFTS meet the most stringent safety standards. The electrical and hydraulic systems feature double safety devices, the cylinders have hose break valves and all movements have pressure control valve safety systems.

The telescopic boom is made of steel sections.

The combination of the boom's qualities plus the "2-speed-system" gives the operator in the basket a stable, safe and functional working place.

The Junior 10/12 is supplied for direct connection to 230 V main supply.



Model Junior12

Technical data

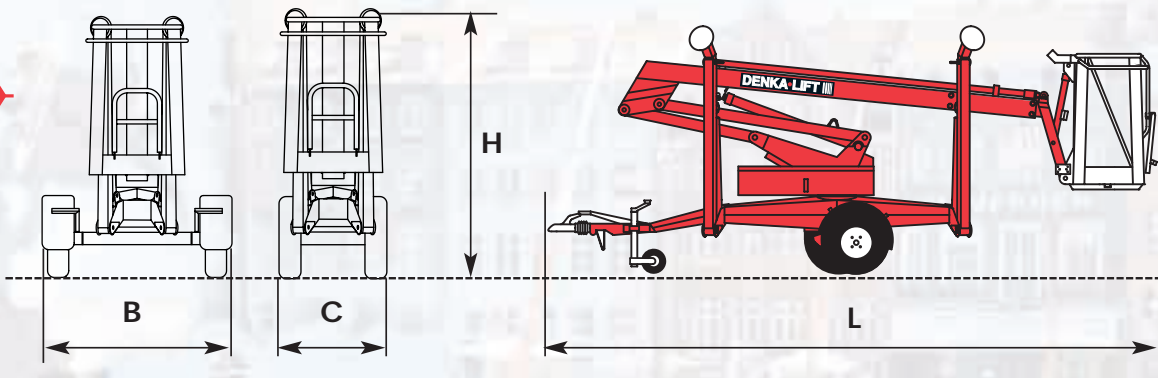

Outrigger cross section

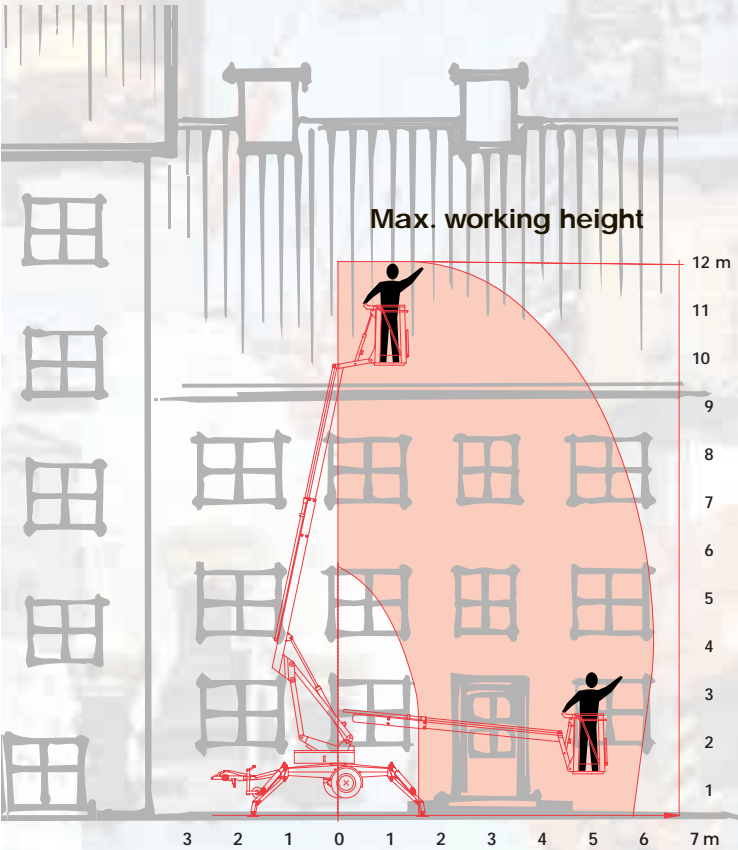
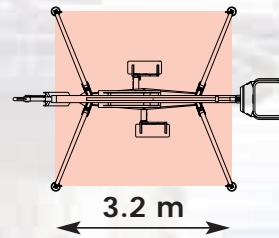

| Standard model | Junior12 |
|-----------------------------|---------------|
| Capacity: | |
| Max. working height A | 12.0 m |
| Max. reach D | 6.7 m |
| Max. load in basket | 120 kg |
| Max. antal personer | 1 |
| Slew movement | cont 360° |
| Transport dimension: | |
| Length L | 5680 mm |
| Height H | 2100/1840 mm |
| Max. width B | 1400 mm |
| Min. width C | 750 mm |
| Min. length | 5050 mm |
| Net weight standard | 985 kg |
| Telescopic boom | 2-stage steel |

STANDARD EQUIPMENT:

- Detachable aluminium basket 900 mm
- 230V power supply
- On/off control 2-speed
- Hydraulic outriggers
- ELCB 30 mA
- Hour counter

EXTRA ACCESSORIES:

- Yellow rotating light
- Special colours
- Yellow flashing light on outriggers
- Biological, degradable and hydraulic oil
- Hydraulic wheel drive