

Range T-HD

Cod. PRP1361

**Description:** Telescopic platform, fully hydraulic with high specifications of strength, reliability and easy maintenance. Specifically designed to fulfill the high standard of quality requested by professional users, ensuring a long working life and a high residual value.

## Performances

Working height mt.		18.30
Max load in the basket kg.	† †   †	250
Max working outreach mt.	† †   †	13.80
Turret rotation °		Continuous
Hose track		External
Controls in the basket		Hydraulic with single levers

## Platform specifications

Steel basket dimensions mt.	1.40x0.70
Fiberglass basket dimensions mt.	1.20x0.70
Basket rotation °	45 + 45
Front outriggers	Inclined
Back outriggers	Inclined
Foot plate gauge min. mt.	2.86



## Assembling

This assembly represents the "multipurpose" version with outriggers slightly outside the vehicle mirrors width. The excellent capacity of levelling allows however high performances and operational possibilities.

---

**Body** Purposely designed assembly to optimize functionality and utilization

---

**Standards** CE certificate

---

**Accessories** There are available a wide range of accessories, many of them are already included as stand machine. It is recommended to contact our sales network for more information.

---

**Other types of assembling and different vehicles** We are in position to propose the same machine with different type of assembly and / or on different types of vehicles. Contact our sales organization to obtain information about all the possible solutions that we are able to offer.

---

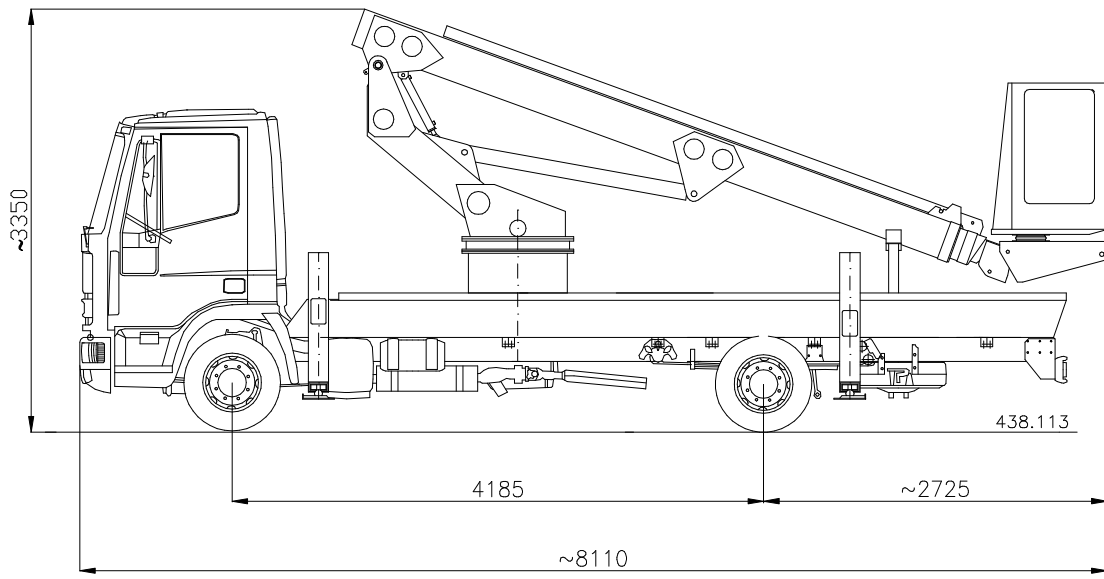
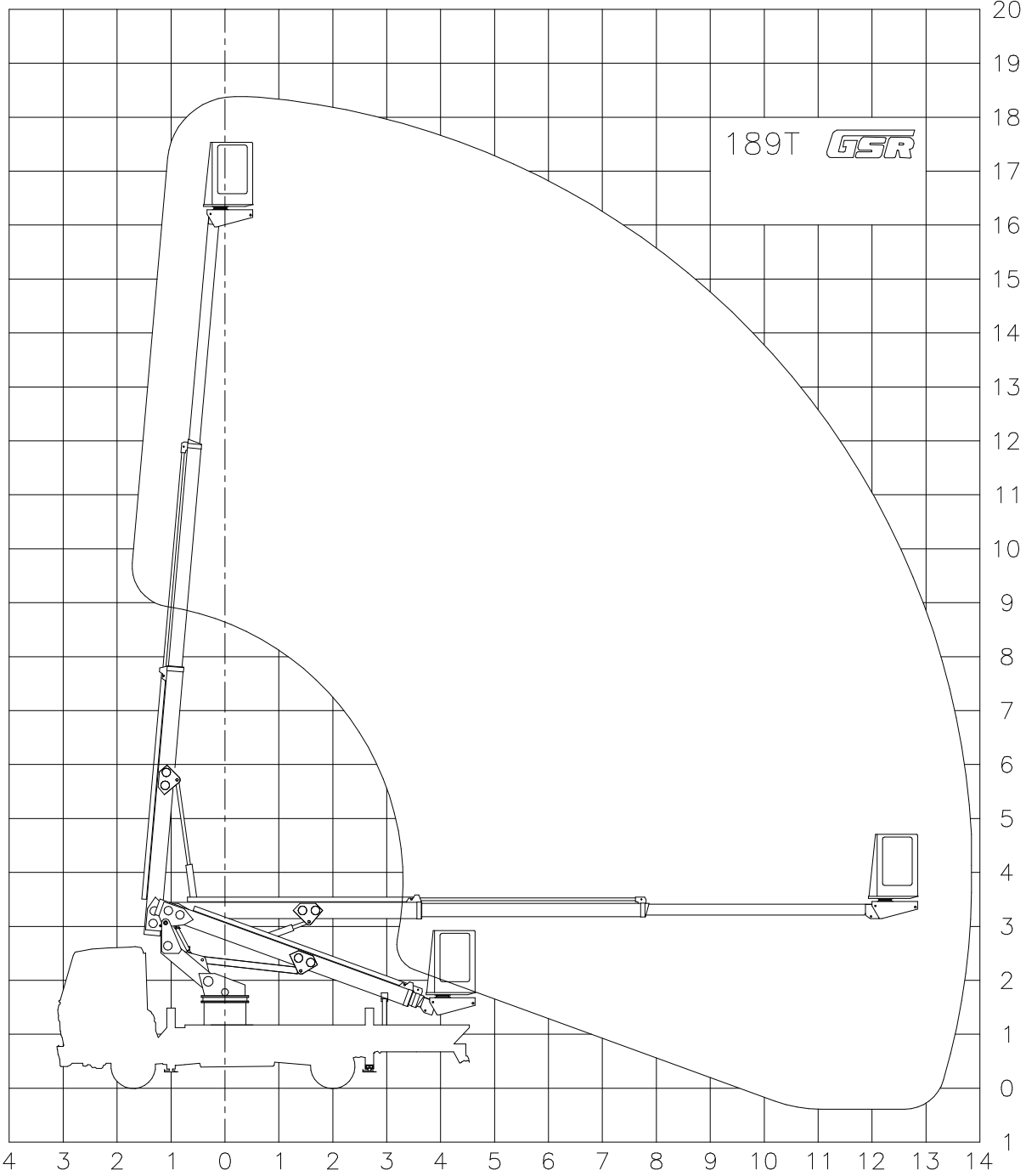

APPROXIMATE DATA - TECHNISCHE ANDERUNGEN VORBEHALTEN  
 DONNEES INDICATIVES - DATI INDICATIVI

AGGIORNAMENTI MODIFICHE	
C	H
B	G
A	F

MAX SAFE WORKING LOAD	 250 KG
MAX NENNTRAGFAHIKGEIT IM KORB	
MAX CHARGE NOMINALE DANS LE PANIER	
MAX PORTATA NOMINALE IN NAVICELLA	

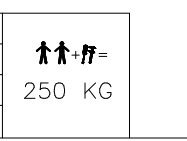

DENOMINAZIONE	189T Basic
IVECO 75E15-75E17 - 7.5T	

DATA	20-03-2003
CODICE	PRP1361