



## Easily Configured to Meet Your Needs:

### PLATFORM OPTIONS

- Standard platform
- Sliding mid-rail extension deck
- Gated extension deck
- Stock Picker platform
- Stock Picker platform with adjustable tray
- Stock Picker platform with rear parcel tray
- Standard AWP platform
- Narrow AWP platform
- Standard fiberglass platform
- Narrow fiberglass platform

### POWER OPTION

- 24 V (4- 6 V 225 Ah batteries)

### TIRE OPTION

- Non-marking tire

## Standard Features

### MEASUREMENTS:

- GR™-15 has 20 ft 8 in (6.47 m) working height
- GR™-15 has 14 ft 8 in (4.47 m) platform height
- Up to 500 lb (227 kg) lift capacity

### POWER:

- Automatic 25 amp battery charger

### PRODUCTIVITY:

- Patented rigid mast system
- Compact base 29.5 x 53 in (75 cm x 1.35 m)
- Standard sliding-midrail platform- 29.5 x 35 in (75 x 88 cm)
- Low 15 in (38 cm) platform entry height
- Adjustable work station tray
- Fully proportional lift and drive controls
- On-board diagnostic system
- AC power to platform
- Descent and tilt alarm
- Auxiliary platform lowering
- Zero inside turning radius
- Dual wheel brakes
- Hydraulic brake release
- Pothole protection
- Hinged rear covers for easy access to all major electrical and hydraulic components
- Large forklift pockets 2.5 x 5.125 in (6.4 x 13 cm)
- Tie down attachment points
- Non-marking tires

## Options and Accessories

### PRODUCTIVITY

- Sliding mid-rail extension deck
- Gated extension deck
- Stock Picker platform with adjustable tray
- Stock Picker rear parcel tray
- Stock Picker bike rack
- Standard AWP platform
- Narrow AWP platform
- Standard fiberglass platform
- Narrow fiberglass platform
- Fluorescent tube caddy
- Motion alarm and flashing beacons
- Automotive horn

### POWER:

- 800 watt inverter (120-230 V AC 50-60 Hz)
- Maintenance-free batteries

Specifications

**Standards Compliance**

- ANSI A92.6
- CSA B354.2
- CE Compliance
- AS 1418.10

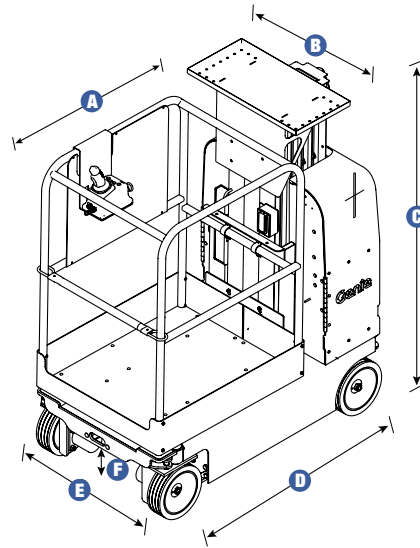

**GR™-15**

|  | US | Metric |
|--|----|--------|
|--|----|--------|

**MEASUREMENTS:**

|                 |            |        |
|-----------------|------------|--------|
| Working height* | 20 ft 8 in | 6.47 m |
| Platform height | 14 ft 8 in | 4.47 m |

|          | Platform dimensions (l x w)                |               |               |
|----------|--|---------------|---------------|
| <b>A</b> | Standard platform                          | 35 x 29.5 in  | 88 x 75 cm    |
| <b>B</b> | Standard platform with extension           | 55 x 29.5 in  | 1.4 m x 75 cm |
|          | Stock Picker platform                      | 35 x 28.75 in | 88 x 73 cm    |
|          | Stock Picker platform with adjustable tray | 56 x 28.75 in | 1.4 m x 73 cm |
|          | Standard AWP platform                      | 27 x 26 in    | 69 x 51 cm    |
|          | Narrow AWP platform                        | 26 x 20 in    | 66 x 51 cm    |
|          | Standard fiberglass platform               | 29 x 26.5 in  | 74 x 67 cm    |
|          | Narrow fiberglass platform                 | 26 x 22 in    | 66 x 56 cm    |
| <b>C</b> | Height- stowed                             | 5 ft 2 in     | 1.57 m        |
| <b>D</b> | Length -stowed                             | 4 ft 5 in     | 1.35 m        |
| <b>E</b> | Width                                      | 2 ft 5.5 in   | 75 cm         |
| <b>F</b> | Ground clearance                           | 2.5 in        | 6.35 cm       |
|          | Lift capacity                              | 500 lbs       | 227 kg        |

**PRODUCTIVITY:**

|                        |                      |          |
|------------------------|----------------------|----------|
| Drive speed - stowed   | 2.5 mph              | 4.0 km/h |
| Drive speed - raised   | 0.5 mph              | 0.8 km/h |
| Gradeability**         | 30%                  |          |
| Turning radius- inside | zero                 |          |
| Controls               | 12 V DC proportional |          |
| Tires                  | non-marking          |          |

**POWER:**

|                           |                         |        |
|---------------------------|-------------------------|--------|
| Power source              | 4- 6 V 225 Ah batteries |        |
| Hydraulic system capacity | 2.2 gal                 | 8.33 L |
| Weight***                 | 2,192 lbs               | 994 kg |

\* The metric equivalent of working height adds 2 m to platform height. U.S. adds 6 ft to platform height.

\*\* Gradeability applies to driving on slopes, see operators manual for details regarding slope rating.

\*\*\* Weight will vary depending on options and/or country standards.