

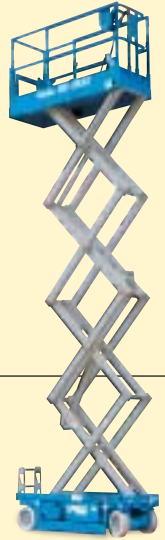

# Electric Self-Propelled Scissor Lift

GS™-2632

○ Its narrow width allows access in hard-to-reach spots. Fits through a standard doorway.



## GS-2632

- 90 degree steering provides zero turning radius and **excellent maneuverability.**
- Single door access 32 in (81.3 cm)
- On-board troubleshooting diagnostics **notify the operators of fault conditions.**
- Variable speed motor **extends battery and motor life** by using only the energy needed to do the required work.
- Weather resistant, impact resistant, molded **Joystick Controller box** operates from the platform or the ground.
- The solid steel deck platform has a **slip-resistant surface.**
- Heavy duty square steel guardrails fold down quickly without tools for **single door access.**

- **Low noise level** allows operation in quiet work environments.
- Swing-out battery box and power module allow **easy access to componentry.**
- Lubrication-free, **service-free pivot points.**

### Standard Features

- GS-2632 has 32 ft (9.92 m) working height
- 39 in (1 m) roll-out platform extension
- Compact 32 in (81.3 cm) width
- 500 lb (227 kg) lift capacity
- Proportional controls for lift and drive functions
- Automatic 25 amp battery charger
- Manual platform lowering valve
- Emergency Stop switches at both platform and ground controls
- Drive speed interlock limits speed while elevated
- Multiple disc brakes provide smooth deceleration
- Manual brake release
- Pothole guards
- Non-marking tires
- AC wiring to platform
- Tilt sensor with an audible alarm
- Beeper horn
- Hour meter

### Options and Accessories

- Motion alarm
- Dual flashing beacons
- Power inverter
- Automotive horn
- Platform swing gate
- Maintenance-free batteries
- Air line to platform
- EE rating

### Standards Compliance

- ANSI/SIA A92.6
- CE compliance option
- AS 1418.10
- CSA CAN3-B354.2-M82

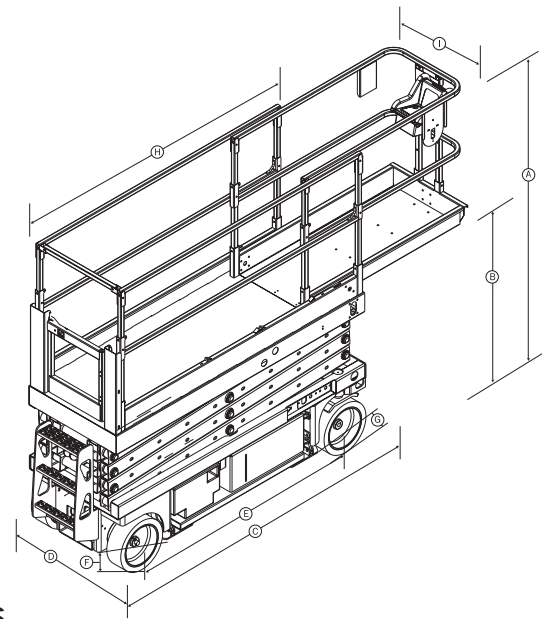

### Specifications

Model	GS-2632	
	US	Metric
Working height*	32 ft	9.92 m
Platform height	26 ft	7.92 m
(A) Height stowed	90 in	2.29 m
Height stowed, rails folded	68 in	1.73 m
(B) Platform height - stowed	46 in	1.17 m
(C) Length - stowed	96 in	2.44 m
Length - platform extended	135 in	3.43 m
(D) Width	32 in	81.3 cm
(E) Wheelbase	73 in	1.85 m
(F) Ground clearance - at machine center	4 in	10.2 cm
(G) Ground clearance - pothole guards deployed	7/8 in	2.2 cm
(H) Platform length	89 in	226 cm
Platform length extended	128 in	325 cm
(I) Platform width	31 in	79 cm
Toeboard height	6 in	15 cm
Lift capacity	500 lb	227 kg
Extension deck lift capacity	250 lb	113 kg
Turning radius inside	zero	
Turning radius outside	92 in	2.34 m
Power source	24V (4-6V, 245AH batteries)	
Drive speed - stowed	2.2 mph	3.5 km/h
Drive speed - raised	0.5 mph	0.8 km/h
Raise/lower speed	37/24 sec	
Controls	24V DC proportional	
Tires (solid rubber, non-marking)	15 x 5 in	38.1 x 12.7 cm
Gradeability	25%	25%
Drive	dual front wheel	
	dual rear wheel	
Multiple disc brakes		
Weight** - ANSI/CSA	5,150 lb	2,336 kg
Weight** - CE/AS	5,520 lb	2,504 kg

\*The metric equivalent of working height adds 2 m to platform height. U.S. adds 6 ft to platform height.

\*\*Certain options and/or country standards will increase weight.