

Genie IWP Super Series Specifications

Industrial Work

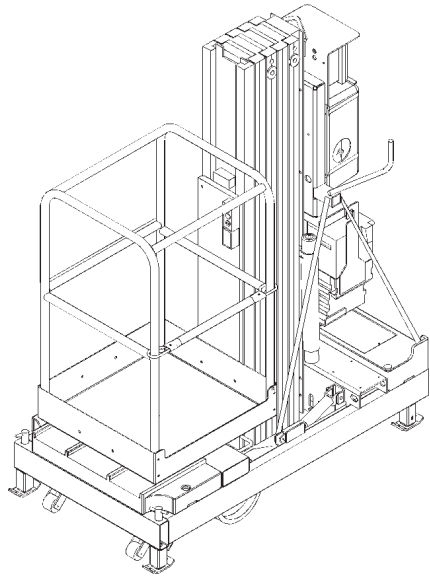

SPECIFICATIONS

MODEL	IWP-20S		IWP-25S		IWP-30S	
	US	Metric	US	Metric	US	Metric
Height - stowed						
Base fully lowered	76 in	1.93 m	76 in	1.93 m	76 in	1.93 m
Base raised	78 in	1.98 m	78 in	1.98 m	78 in	1.98 m
Length - Standard Base	60 in	1.52 m	60 in	1.52 m	n/a	n/a
Length - Wide Base	60 in	1.52 m	60 in	1.52 m	60 in	1.52 m
Width - Standard Base	32 in	81 cm	32 in	81 cm	n/a	n/a
Width - Wide Base	40 in	1.02 m	40 in	1.02 m	40 in	1.02 m
Working height max	26 ft 5 in	8.05 m	30 ft 5 in	9.27 m	35 ft 6 in	10.82 m
Platform height max	20 ft 5 in	6.22 m	24 ft 5 in	7.44 m	29 ft 6 in	9 m
Outreach ¹	26 in	66 cm	n/a	n/a	n/a	n/a
Corner access ²	6 in	15 cm	6 in	15 cm	7 in	18 cm
Power source - DC model	12V	12V	12V	12V	12V	12V
Power source - AC model	110V or 220V		110V or 220V		110V or 220V	
Lift capacity- Standard and Wide Base						
ANSI, CE	350 lb	159 kg	350 lb	159 kg	350 lb	159 kg
CSA	300 lb	136 kg	300 lb	136 kg	n/a	n/a
Lift capacity with outreach option - Standard and Wide Base						
ANSI, CE, CSA	300 lb	136 kg	n/a	n/a	n/a	n/a
Machine weight - Standard Base (AC/DC)						
ANSI	1,028/1,112 lb		1,331/1,415 lb		n/a	n/a
CE	466/504 kg		604/642 kg		n/a	n/a
CSA	1,283/1,367 lb		1,331/1,415 lb		n/a	n/a
CE	582/620 kg		604/642 kg		n/a	n/a
Machine weight with outreach - Standard Base (AC/DC)						
ANSI, CE	1,348/1,432 lb		n/a	n/a	n/a	n/a
CE	611/650 kg		n/a	n/a	n/a	n/a
Machine weight - Wide Base (AC/DC)						
ANSI	1,086/1,170 lb		1,134/1,218 lb		1,146/1,362 lb	
CE	493/531 kg		514/552 kg		520/618 kg	
CSA	1,283/1,367 lb		1,114/1,198 lb		1,146/1,362 lb	
CE	582/620 kg		505/543 kg		520/618 kg	
CSA	1,266/1,350 lb		1,644/1,728 lb		n/a	
CE	574/612 kg		746/784 kg		n/a	
Machine weight with outreach - Wide Base (AC/DC)						
ANSI	1,199/1,283 lb		n/a	n/a	n/a	n/a
CE	544/582 kg		n/a	n/a	n/a	n/a
CSA	1,348/1,432 lb		n/a	n/a	n/a	n/a
CE	611/650 kg		n/a	n/a	n/a	n/a
CSA	1,331/1,415 lb		n/a	n/a	n/a	n/a
CE	604/642 kg		n/a	n/a	n/a	n/a
PLATFORM DIMENSIONS (L x W x H)						
Standard Platform	27 x 26 x 44 ¾ in		69 cm x 66 cm x 1.14 m		69 cm x 66 cm x 1.14 m	
Gated Standard Platform	27 x 26 x 44 ¾ in		69 cm x 66 cm x 1.14 m		69 cm x 66 cm x 1.14 m	
Gated Ultra-Narrow Platform	22 x 18 x 44 ¾ in		56 cm x 46 cm x 1.14 m		56 cm x 46 cm x 1.14 m	
Gated Narrow Platform	26 x 20 x 44 ¾ in		66 cm x 51 cm x 1.14 m		66 cm x 51 cm x 1.14 m	
Standard Fiberglass Platform	29 x 26 ½ x 43 ½ in		74 cm x 67 cm x 1.1 m		74 cm x 67 cm x 1.1 m	
Narrow Fiberglass Platform	26 x 22 x 43 ½ in		66 cm x 56 cm x 1.1 m		66 cm x 56 cm x 1.1 m	

STANDARD FEATURES

- AC or DC power options
- Wide forklift pockets
- Overhead crane attachment point
- Auxiliary platform lowering feature
- AC wiring to platform
- Locking key switch
- Most rigid mast in the industry
- Meets or exceeds ANSI A-92.3, CE and CSA safety standards

Genie Industries

¹ Gated Ultra Narrow and Fiberglass Platforms not available with Outreach option.

² Corner of platform top rail to corner of wall with ability to rotate leveling jack handle.