



Industrial Work Platform Super Series

IWP™ SUPER SERIES

○ Stability
without
outriggers.



The platform that performs with more height, more options and no outriggers.

The Genie IWP Super Series offers more of what you're looking for in a push-around lift: working heights of up to 35 ft 6 in (11 m) without outriggers, a stable work platform and many other standard features and options. The Genie IWP is unmatched in strength, stability and reliability, and takes only seconds to set up.



Standard Features of the IWP Super Series:

Built-in level sensing

The outer base frame is hydraulically lowered to the ground for exceptional stability. If you're not level, the unique sensor system will detect it. All interlocks are conveniently displayed on the Ground Controls to confirm proper set-up. Two front integral leveling jacks provide an additional two inches of adjustability.

The most rigid mast in the industry

Our heavy duty lifting chains have a safety factor of greater than 10 to 1. They are used throughout the entire mast system for strength, reliability and low maintenance.

Choose from Standard and Wide Base models

Standard Base of 60 x 32 in (1.52 m x 81 cm). Easily rolls through standard doorways. Available models: IWP-20S and IWP-25S.

Wide Base models of 60 x 40 in (1.52 x 1.02 m). These roll through double doorways typically found on industrial job sites. Available models: IWP-20S, IWP-25S and IWP-30S.

Wide Forklift Pockets

5³/₄ x 2³/₄ in (14 x 7 cm) pockets for convenient forklift transport.

Overhead Crane Attachment Point

A steel bracket located on the mast provides an attachment point for crane transport.

Tie-Downs

Sturdy tie-down attachment points are provided for ease of transport.

Ground Controls

The platform can be lowered from the ground controls. A locking key prevents unauthorized use. Controls are protected by a steel hood. Indicator light signals a low battery.

IWP Super Series Standard Base model with the Standard Aluminium Platform, Outreach option, and Power Wheel Assist option.



Ground Controls include a low-battery indicator.



The Genie IWP gives you the lowest entry height in its class.*



The Gated Narrow platform easily fits through ceiling tiles.



Foot pedal raises the base for easy maneuverability.



Removable Battery Box.



The Narrow Fiberglass platform is the smallest fiberglass platform available.

Platform Controls

Both AC and DC models are equipped with an auxiliary platform lowering feature that enables descent from the platform or ground controls in the event of a power failure. Large control buttons feature a dual-activated up/down switch. The Ground Fault Interrupt power receptacle provides for safe, convenient use of power tools. All safety and instructional decals are clearly visible.

* CE compliance models are for indoor use only.

Options and Accessories

Outreach Package

This option adds over 2 ft (61 cm) of horizontal outreach getting you up and over shelves, machinery and equipment. This option is available for use with any 20 ft (6.1 m) IWP Super Series equipped with a Standard, Gated Standard, Gated Narrow or Front Entry Gated Narrow platform.

Power Wheel Assist

This feature allows you to easily move your unit. A convenient thumb-rocker switch activates the hydraulic drive motor for forward and reverse movement. Available on DC models only.

Fluorescent Tube Caddy

Provides a safe and convenient storage pocket for fluorescent lights.

Tool Tray

Provides a convenient location for your tools in the platform.

Operational Warning Light and Descent Alarm Package

These alert personnel when lowering the IWP platform.

Platform Locating Laser Light

Attaches directly to the platform and projects a laser light on the overhead work area, allowing you to position the unit directly beneath it.

Dual Battery Package (standard with Power Wheel Assist option)

An extra battery for extended use. Ideal for heavy-duty applications.

Power Source Options

AC Power Options

Available in:
110/50-60 Hz
220/50-60 Hz

DC Power Options

All DC models include an automatic “smart” charging system enclosed in a removable, gimbal-mounted battery pack for convenient off-site charging.

Available in:

- 110/60 Hz
- 110/230 Hz Worldwide model with a voltage adjustable, hertz compensating charging system.

Platform Options

Gated Standard Platform

This 27 x 26 in (69 x 66 cm) gated platform provides “step-in” entry.

Gated Ultra Narrow Platform

The 22 x 18 in (56 x 46 cm) gated platform is the narrowest available.

Gated Narrow Platform

The 26 x 20 in (66 x 51 cm) gated platform is ideal for access through standard ceiling tile and other small openings.

Front Entry Gated Narrow Platform

The 20 x 26 in (51 x 66 cm) platform provides a gated front entry.

Front and Side Entry Extra-Large Platform

The largest platform in its class at 30 x 28 in (76 x 71 cm). It provides a gated front entry and sliding mid-rail side entry.

Standard Fiberglass Platform

Measures 29 x 26^{1/2} in (74 x 67 cm).

Narrow Fiberglass Platform

Measures 26 x 22 in (66 x 56 cm).



Outreach option.



Power Wheel Assist option.

Standard Platform

The 27 x 26 in (69 x 66 cm) sliding mid-rail entry platform is the largest standard sized platform in the industry. Excellent for general purposes, it is included with Standard and Wide Base models.



Standard Aluminum Platform



Gated Standard Aluminum Platform



Gated Ultra-Narrow Aluminum Platform



Standard Fiberglass Platform



Narrow Fiberglass Platform

The Gated Narrow, Front Entry Gated Narrow and Front and Side Entry Extra-Large are not pictured. The Gated Ultra Narrow, Front and Side Entry Extra-Large, Standard Fiberglass and Narrow Fiberglass Platforms are not available with the Outreach option.

Standard Features

- Standard base of 60 x 32 in (1.52 m x 81 cm), easily rolls through standard doorways.
- Standard platform of 27 x 26 in (69 x 66 cm), the **largest standard sized platform in the industry.**
- **The most rigid mast in the industry,** designed for strength, reliability and low maintenance.
- **Built-in level sensing.** A unique sensor system detects if the unit is not level.
- **Power failure protection.** All AC and DC models are equipped with an auxiliary platform lowering feature.

Options and Accessories

- Outreach package 26 in (66 cm)
- Power Wheel Assist
- Platform-locating laser light
- Warning light and descent alarm
- AC/DC power
- Platform options
- Fluorescent tube caddy
- Tool Tray
- Dual battery package

Standards Compliance

- ANSI/SIA A92.3
- CSA CAN3-B354.1-M82 (IWP-20S and IWP-25S wide base models only)
- CE indoor compliance
- AS 1418.10-1996

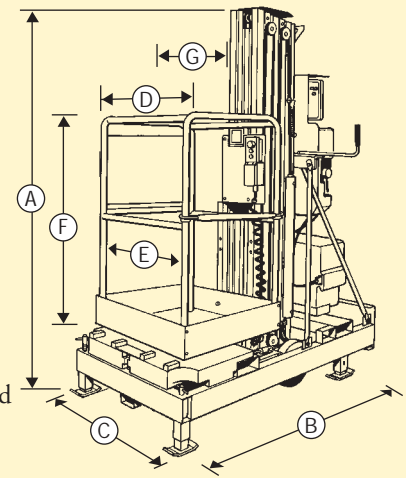

Model	IWP-20S		IWP-25S		IWP-30S	
	US	Metric	US	Metric	US	Metric
(A) Height - stowed						
base fully lowered	76 in	1.93 m	76 in	1.93 m	76 in	1.93 m
base raised	78 in	1.98 m	78 in	1.98 m	78 in	1.98 m
(B) Length - Standard Base	60 in	1.52 m	60 in	1.52 m		
Length - Wide Base	60 in	1.52 m			60 in	1.52 m
(C) Width - Standard Base	32 in	81 cm	32 in	81 cm		
Width - Wide Base	40 in	1.02 m	40 in	1.02 m	40 in	1.02 m
Working height max*	26 ft 5 in	8.22 m	30 ft 5 in	9.44 m	35 ft 6 in	11 m
Platform height max	20 ft 5 in	6.22 m	24 ft 5 in	7.44 m	29 ft 6 in	9 m
(G) Outreach ¹	26 in	66 cm				
Corner Access ²	6 in	15 cm	6 in	15 cm	7 in	18 cm
Power source - DC model	12 V	12 V	12 V	12 V	12 V	12 V
Power source - AC model	110 or 220 V	110 or 220 V	110 or 220 V	110 or 220 V	110 220 V	110 or 220 V
Lift capacity - Standard and Wide Base						
ANSI, CE	350 lb	159 kg	350 lb	159 kg	350 lb	159 kg
CSA	300 lb	136 kg	300 lb	136 kg		
Lift capacity with outreach option - Standard and Wide Base						
ANSI, CE, CSA	300 lb	136 kg				
Machine weight - Standard Base (AC/DC)						
ANSI	1,028/1,112 lb	466/504 kg	1,331/1,415 lb	604/642 kg		
CE	1,283/1,367 lb	582/620 kg	1,331/1,415 lb	604/642 kg		
Machine weight with outreach - Standard Base (AC/DC)						
ANSI, CE	1,348/1,432 lb	611/650 kg				
Machine weight - Wide Base (AC/DC)						
ANSI	1,086/1,170 lb	493/531 kg	1,134/1,218 lb	514/552 kg	1,146/1,362 lb	520/618 kg
CE	1,283/1,367 lb	582/620 kg	1,114/1,198 lb	505/543 kg	1,146/1,362 lb	520/618 kg
CSA	1,266/1,350 lb	574/612 kg	1,644/1,728 lb	746/784 kg		
Machine weight with outreach - Wide Base (AC/DC)						
ANSI	1,199/1,283 lb	544/582 kg				
CE	1,348/1,432 lb	611/650 kg				
CSA	1,331/1,415 lb	604/642 kg				
Platform Dimensions	(D) x (E) x (F)	(D) x (E) x (F)	Platform Dimensions	(D) x (E) x (F)	(D) x (E) x (F)	(D) x (E) x (F)
Standard Platform	27 x 26 x 44 ³ / ₄ in	69 x 66 x 114 cm	Front Entry Gated Narrow Platform	20 x 26 x 44 ³ / ₄ in	51 x 66 x 114 cm	
Gated Standard Platform	27 x 26 x 44 ³ / ₄ in	69 x 66 x 114 cm	Front and Side Entry Extra-Large Platform	30 x 28 x 44 ³ / ₄ in	76 x 71 x 114 cm	
Gated Ultra-Narrow Platform	22 x 18 x 44 ³ / ₄ in	56 x 46 x 114 cm	Standard Fiberglass Platform	29 x 26 ¹ / ₂ x 43 ¹ / ₂ in	74 x 67 x 110 cm	
Gated Narrow Platform	26 x 20 x 44 ³ / ₄ in	66 x 51 x 114 cm	Narrow Fiberglass Platform	26 x 22 x 43 ¹ / ₂ in	66 x 56 x 110 cm	

¹ Gated Ultra Narrow, Front and Side Entry Extra-Large and Fiberglass Platforms are not available with the Outreach option. ² Corner of platform top rail to corner of wall with ability to rotate leveling jack handle.
 * The metric equivalent of working height adds 2 m to platform height. U.S. adds 6 ft to platform height.