

Genie Z-45/25 RT & Z-45/25J RT Specifications

Articulated Booms

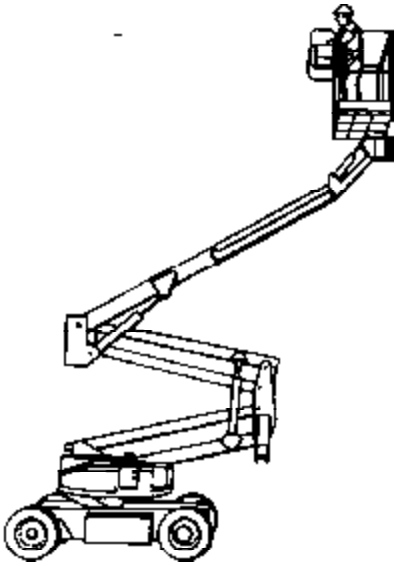

SPECIFICATIONS

	Z-45/25 RT		Z-45/25JRT	
	<i>US</i>	<i>Metric</i>	<i>US</i>	<i>Metric</i>
Working height*	51 ft 8 in	15.9 m	51 ft 6 in	15.9 m
Platform height	45 ft 8 in	13.9 m	45 ft 6 in	13.9 m
Height - stowed	6 ft 10 in	2.08 m	6 ft 10 in	2.08 m
Length - stowed	18 ft	5.5 m	22 ft 3 in	6.8 m
Width	7 ft 4 in	2.24 m	7 ft 4 in	2.24 m
Wheelbase	6 ft 8 in	2.03 m	6 ft 8 in	2.03 m
Ground clearance - center	13 in	33 cm	13 in	33 cm
Ground clearance - min	10 in	25 cm	10 in	25 cm
Platform length	30 in	76 cm	30 in	76 cm
Platform width	72 in	1.83 m	72 in	1.83 m
Horizontal reach max	24 ft 6 in	7.5 m	25 ft 3 in	7.7 m
Up and over clearance	22 ft 9 in	6.9 m	22 ft 9 in	6.9 m
Lift capacity	500 lb	227 kg	500 lb	227 kg
Turning radius - inside	4 ft 6 in	1.37 m	4 ft 6 in	1.37 m
Turntable rotation	359°		359°	
Tailswing	zero		zero	
Platform rotation	180°		160°	
Power source	Ford LRG 425 EFI Gas/LPG 82 hp (61 kw) Deutz Diesel F3L 1011 36 hp (27 kw) Perkins Diesel 104-22 50 hp (37 kw)			
Drive speed - stowed	4.8 mph	7.7 km/h	4.8 mph	7.7 km/h
Drive speed - raised	0.6 mph	1 km/h	0.6 mph	1 km/h
Lift speed to full height	45 sec		45 sec	
Controls	12V DC proportional		12V DC proportional	
Auxiliary power unit	12V DC		12V DC	
Tires	14-17.5		14-17.5	
Gradeability - 4x4	45%		45%	
Gradeability - 4x2	30%		30%	
Hydraulic tank capacity	25 gal	95 litre	25 gal	95 litre
Fuel tank capacity	14.3 gal	54 litre	14.3 gal	54 litre
Weight - 4x4**	13,800 lb	6,261 kg	14,000 lb	6,352 kg
Weight - 4x2**	13,600 lb	6,171 kg	13,800 lb	6,261 kg

STANDARD FEATURES

- Over 51 ft (15.9 m) of working height
- Over 24 ft (7.3 m) horizontal reach
- 500 lb (227 kg) lift capacity
- Fully proportional controls
- 180° hydraulic platform rotation on Z-45/25 models
- 160° hydraulic platform rotation on Z-45/25J models
- Two- or four-wheel drive
- AC wiring to platform
- Drive enable system
- Auxiliary power unit
- Hour meter
- Tilt alarm
- Horn

* The metric equivalent of working height adds 2 m to platform height. U.S. adds 6 ft to platform height.

** Weight will vary depending on options and/or country standards.