

# nifty

## HR17N

### SELF PROPELLED ACCESS PLATFORM



**17.20m (56ft 5in)**  
Working height

**9.60m (31ft 6in)**  
Working Outreach

**1.50m Narrow Chassis**  
Allows operation in  
confined areas

**Bi-Energy Available**  
Optimising utilisation

**225kg SWL**  
Extra capacity for tools  
and materials

**Telescopic Upper Boom**  
Greater accuracy when  
positioning platform

**Platform Rotation  
& Fly-Boom**  
Improving manoeuvrability  
on site



[niftylift.com](http://niftylift.com)

**facelift**  
access and safety made easy

# nifty

## Heightrider 17N

The Nifty **Height Rider 17N** (HR17N) will lift 2 men and their tools to a working height of 17.20m or an outreach of 9.60m. Its impressive 100° platform rotation and 150° flyboom provide exceptional control when positioning the platform making tasks quicker and easier to perform. A super narrow 1.50m width base enables travel in restricted access areas and optional Bi-Energy power makes the **HR17N** even more versatile, allowing it to work both inside and out with equal ease.

### SAFETY FEATURES

- Manual Recovery with Hand Pump
- Automatic Fail-Safe Brakes
- CE Mark
- Tilt Alarm
- Solid Tyres
- Dual Harness Points
- Dual Controls (platform & base)
- Lock Valves on all Hydraulic Cylinders

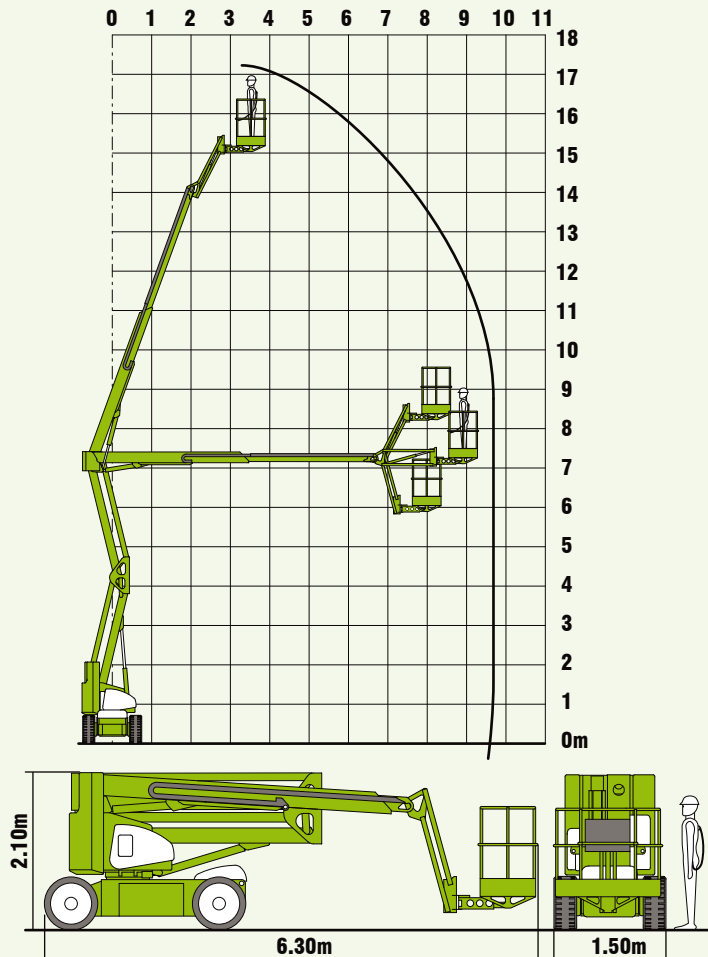
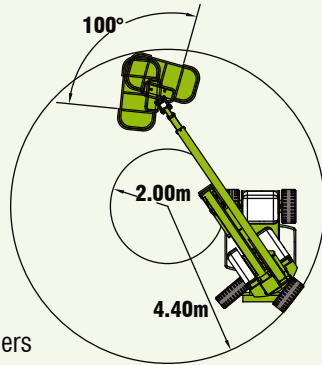

Due to a policy of continuing development and improvement, Niftylift reserves the right to change any specification without notice. Please confirm exact specification before ordering.



The Nifty **HR17N's** narrow base and outstanding outreach are ideal for tasks where floor space is limited or crowded and optional non-marking tyres make it perfect for industrial or maintenance work.

### SPECIFICATIONS

<b>Working Height</b>	17.20m	56ft 5in
<b>Platform Height</b>	15.20m	49ft 10in
<b>Working Outreach</b>	9.60m	31ft 6in
<b>Slew</b>	360°	
<b>Fly-Boom Arc</b>	150°	
<b>Width</b>	1.50m	4ft 11in
<b>Height</b>	2.10m	6ft 11in
<b>Length - Stowed</b>	5.00m	16ft 5in
<b>- Overall</b>	6.30m	20ft 8in
<b>Minimum Weight</b>	7,200kg*	15,900lbs*
<b>Turning Radius - Inside</b>	2.00m	6ft 7in
<b>- Outside</b>	4.40m	14ft 5in
<b>Platform Rotation</b>	100°	
<b>Platform Capacity</b>	225kg	
<b>Platform Size</b>	1.50m x 0.70m	4ft 11in x 2ft 4in
<b>Drive Speed</b>	4kph	2.5mph
<b>Gradeability</b>	25%	
<b>Control System</b>	Fully Proportional Hydraulic	
<b>Power System</b>	Battery Only	
	LPG Only	
	Bi-Energy - Battery & Diesel	
	(Kubota 722 18Hp)	

\* Weights may vary according to specification, please confirm before ordering.

**Head Office**  
Westside, London Road,  
Hickstead, West Sussex,  
RH17 5LZ

T 01444 88 11 88  
F 01444 88 11 99  
E [hiredesk@facelift.co.uk](mailto:hiredesk@facelift.co.uk)  
W [facelift.co.uk](http://facelift.co.uk)

**facelift**  
access and safety made easy