

COMPACT 8/10 N



- 78.4 in (1.99 m) stowed height (Compact 8).
- 32 in (0.81 m) width.
- 770 lb (350 kg) platform capacity.
- 4.9 in (12.5 cm) ground clearance.
- Security system with Pot Hole protection.



COMPACT 8/10 N

Electric scissor lifts

The Haulotte® advantages

- Stowed height allows passage through standard doorways
- 32 in (0.81 m) width allows operation in the most congested areas
- 7 ft 10 in (2.37 m) outside turning radius ensure excellent manoeuvrability
- 4.9 in (12.5 cm) ground clearance allows for both inside and outside use
- Pot Hole protection and load limiter in cage ensures maximum safety
- Driveable at full height
- High operating autonomy
- Robust, reliable and easy to maintain design

STANDARD FEATURES

- Non marking tyres
- Folding guardrails (Compact 10N)
- 3 ft (0.92 m) platform extension
- 2° tilt alarm
- Load limiter in cage
- 2 drive speeds
- 2 wheel drive and steer (front)
- Free wheeling device
- 24 V - 4 x 6 V - batteries
- 30 amp battery charger
- Battery charge indicator
- Hourmeter
- Horn in cage
- Towing hooks / lifting eyes
- Emergency lowering system
- Safety harness anchor points

OPTIONS & ACCESSORIES

- Motion alarm
- 230 V socket in platform
- 59 in (1.5 m) extension from upper control box
- Working light
- Flashing light

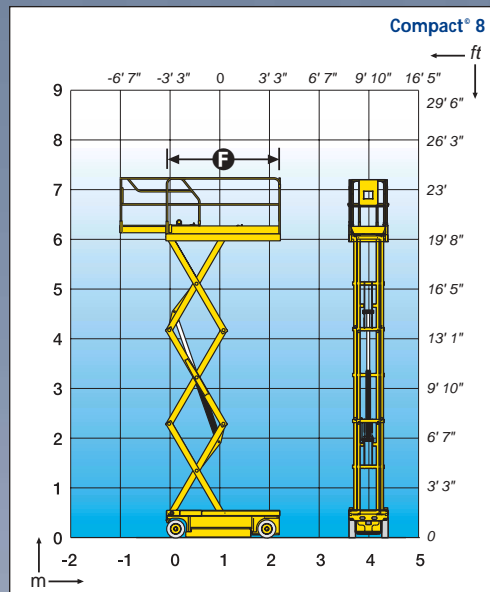
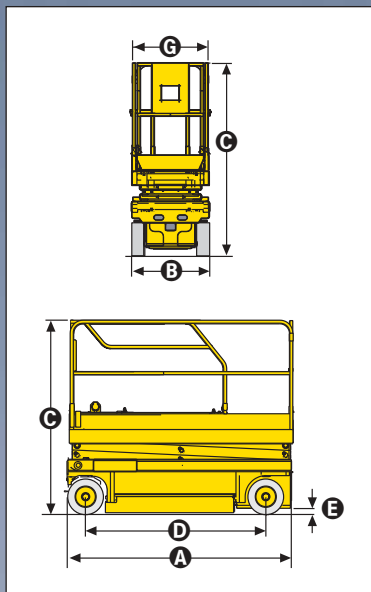

SPECIFICATIONS

	Compact 8		Compact 10 N	
Working height	26 ft 1 in	8.18 m	32 ft 10 in	10 m
Platform height	20 ft 3 in	6.18 m	26 ft 3 in	8 m
Driveable at full height	20 ft 3 in	6.18 m	26 ft 3 in	8 m
Platform capacity (without extension)	770 lb - 350 kg			
A Stowed length	91 in - 2.31 m			
with access steps	98 in - 2.48 m			
B Width	32 in - 0.81 m			
C Stowed height	78.4 in	1.99 m	7 ft 1 in	2.17 m
Transport height	35 in	0.87 m	39 in	0.99 m
D Wheelbase	6 ft 1 in - 1.86 m			
E Ground clearance	4.9 in - 12.5 cm			
with deployed Pot Hole	1 in - 2.5 cm			
F x G Platform size	91 in x 32 in - 2.3 m x 0.8 m			
Extension : Size	3 ft - 0.92 m			
Extension : Capacity	330 lb - 150 kg			
Drive speed	0.6 mph - 1.8 mph - 1 km/h - 3.0 km/h			
Inside turning radius	0	0	13 in	0.34 m
Outside turning radius	7 ft 10 in - 2.37 m			
Lift / lower speed (sec.)	35 / 40 sec		45 / 45 sec.	
Gradeability	23%			
Tilt Alarm	2°			
Controls	Proportional			
Batteries (amp/h)	180		209	
Tyres (solid / non marking)	15 x 5 x 2 in - 38 x 13 x 5 cm			
Hydraulic tank	7 gal - 25 l			
Weight	3,815 lb	1.730 kg	4,762 lb	2.160 kg

AS1418.10

