

OPTIMUM 6/8



Optimum 8

- Stowed height 1.91 m (6ft 3in), width 0.76 m (2ft 5in).
- Platform capacity 280 kg (617 lb) (Optimum 6).
- Security system with Pot Hole protection.

ISO 9001
GROUP
PINGUELY
HAULOTTE



ARTICULATED BOOMS



VERTICAL MASTS



TELESCOPIC BOOMS



SCISSOR LIFTS



TRAILERS

Haulotte®

ON THE UP

The Haulotte® avantages

- Compact : stowed height for easy travel through standard "doorways"
- Length : 1.88 (6 ft 2 in) and width 0.76 m (2 ft 5 in) allow operation in the most congested areas
- Outside turning radius 1.70 m (5 ft 6 in) ensures excellent manoeuvrability
- 8 cm (3 in) ground clearance allows for both inside and outside uses
- Pot Hole protection ensures maximum safety
- High operating autonomy
- Robust reliable and easy to maintain design

STANDARD FEATURES

- Non marking tyres
- 0.92 m (3ft) platform extension
- 2° tilt alarm
- 2 drive speed
- 2 front wheel drive and steer
- Free weeling device
- 24 V - 4x6 V - 180 Ah batteries
- 30 Amp battery charger
- Battery charge indicator
- Hour meter
- Horn
- Towing hooks / lifting eyes
- 2 hooks for safety harness
- 2 emergency stop buttons and 2 control boxes
- Emergency lowering system

OPTIONS & ACCESSORIES

- Motion alarm
- 230 V power to platform
- Flashing light
- Working light
- 1,5 m extension from control box

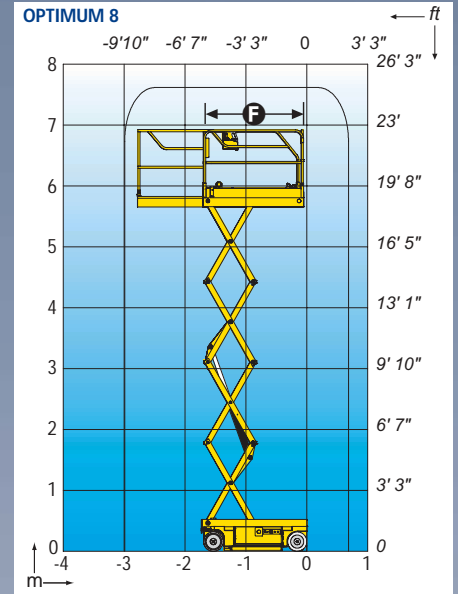
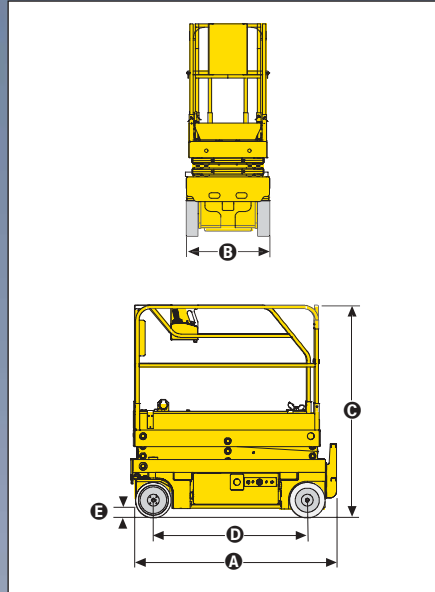

SPECIFICATIONS

	OPTIMUM 6		OPTIMUM 8	
Working height	6.45 m	20 ft 7 in	7.76 m	25 ft 5 in
Platform height	4.45 m	14 ft 7 in	5.76 m	18 ft 11 in
Driveable at full height	6.45 m	21 ft 2 in	7.6 m	25 ft
Platform capacity	280 kg	617 lb	230 kg	507 lb
A Stowed length	1.73 m	8 ft 8 in	1.73 m	5 ft 8 in
With access steps	1.88 m - 6 ft			
B Width	0.76 m - 2 ft 6 in			
C Stowed height (guardrails)	1.91 m	6 ft 3 in	2 m	6 ft 7 in
Stowed height (platform)	0.80 m	2 ft 7 in	0.89 m	3 ft
D Wheelbase	1.38 m - 4 ft 6 in			
E Ground clearance	8 cm - 3 in			
With deployed Pot Hole	2.2 cm - 0.9 in			
F Platform size	1.65 x 0.7 m - 65 in x 28 in			
Extension: size	0.92 m - 3 ft			
Drive speed	0.6-4.55 km/h - 0.37-2.83 mph			
Outside turning radius	1.70 m - 5 ft 7 in			
Lift / lower speed (sec.)	25/18		30/23	
Gradeability	25%			
Tilt alarm	2°			
Controls	Proportional			
Batteries	180 Amp/h			
Tyres (solid / non marking)	Solid Dia 317			
Hydraulic tank	18 l / 4 gal			
Weight	1335 kg	2,943 lb	1 420 kg	3,130 lb

