

10.5 E



www.ommelift.dk

COMPACT AND FLEXIBLE TRAILER-MOUNTED



OMMELIFT



Quality since 1906

Mini 10.5 E

Trailer-mounted

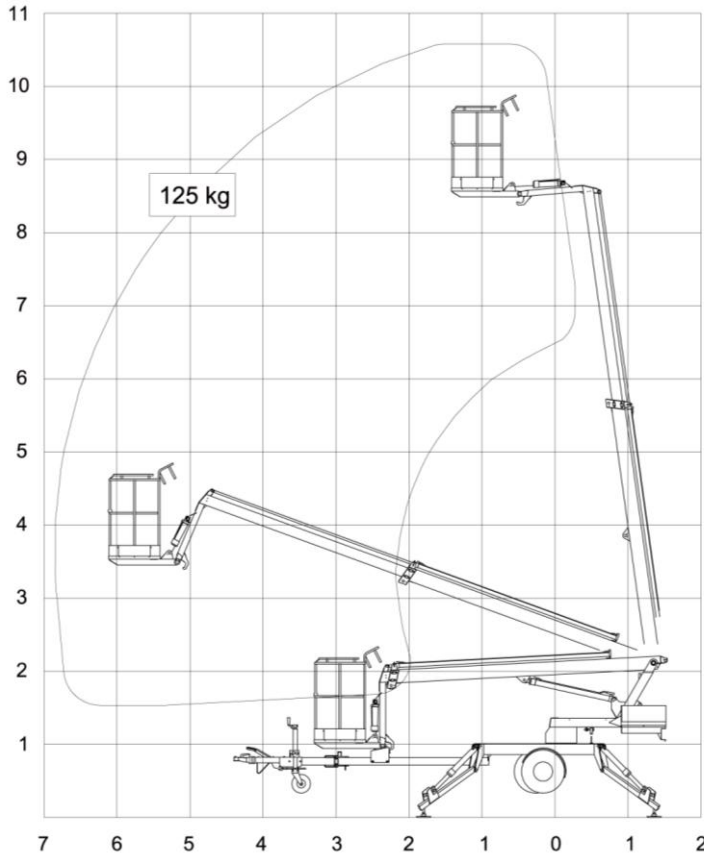

Technical data:	Mini 10.5 E
Max. working height	10.50 m
Max. outreach	6.80 m
Max. basket load	125 kg
Basket size	0.7x0.7x1.1 m
Rotation	± 355°
Power supply	230V/10A
Transport length	5.90 m
Transport height	1.95 m
Transport width	1.20/0.78 m
Operational width	3.40 m
Total weight ca.	1050 kg
230 V outlet in basket	+
2 – step controls	+
Adjustable transport width	+
Propulsion	0

COMPACT AND FLEXIBLE



Easy transport



Narrow



230 V outlet in basket



Flyboom

- Type Mini 10.5 E is driven by a 230 Volt-electronic motor which can be connected to a mains with a fuse of only 10 A. Type Mini 10.5 E is particularly suited for continuous operation.
- Standard features include hydraulic stabilizers and 2-step dual controls to ground and basket. Design features include a basket mounting that forms a "fly" boom mounted to the top boom section and gives increased outreach over roof edges or other obstacles. The specially designed steel booms made from high and broad profiles allow a great outreach with an exceptional degree of stability and rigidity. The wiring is protected inside the boom system.
- Adjustable travelling width: As standard the lift is equipped with an adjustable wheel axle which means that the lift with the wheels in the outer position is very stable during towing. Furthermore, it is possible to reduce the travelling width, so that the lift can pass through a 0.8 m doorway.

Head Office
Westside, London Road,
Hickstead, West Sussex,
RH17 5LZ

T 01444 88 11 88
F 01444 88 11 99
E hiredesk@facelift.co.uk
W facelift.co.uk

facelift
access and safety made easy