

Model

# 150HAX

ARTICULATING  
BOOM LIFT

**facelift**  
access and safety made easy

**JLG**

## Features

36 x 96 in. (0.91 x 2.44 m) Platform  
Inward Swinging Gate  
Hydraulic Platform Rotator  
110V-AC Receptacle in Platform  
5 Degree Tilt Indicator Light  
Intercom System  
12V-DC Auxiliary Power  
Proportional Controls  
Lifting/Tie Down Lugs  
Hourmeter  
All Motion Alarm  
Platform Capacity Indicator Gauge  
Moveable Ground Control Box  
Manual Descent

## Accessories & Options

Hydraulic Power Tool Circuit  
5 Degree Tilt Alarm  
Soft Bounce System  
Light Package<sup>1</sup>  
Hostile Environment Kit<sup>2</sup>  
Flashing Amber Beacon

1. Includes head and tail lights, and platform worklights.

2. Includes console cover, boom wiper and cylinder bellows.

Note: Some options may increase lead time, and some option combinations may not be available.



### The world's largest self-propelled articulating boom lift

- The highest platform height—150 ft (45.72 m).
- The longest outreach—79 ft 3 in. (24.16 m).
- The most up and over height—80 ft (24.38 m).

### Increased maneuverability

- Extendable axles provide stability without excessive counterweight to enable travel from the fully elevated position.
- Four wheel steer/crab steer provides a tight turning radius and more precise positioning.
- 165 degree power rotator rotates basket to the left or right for improved access to work areas.

### Specifications

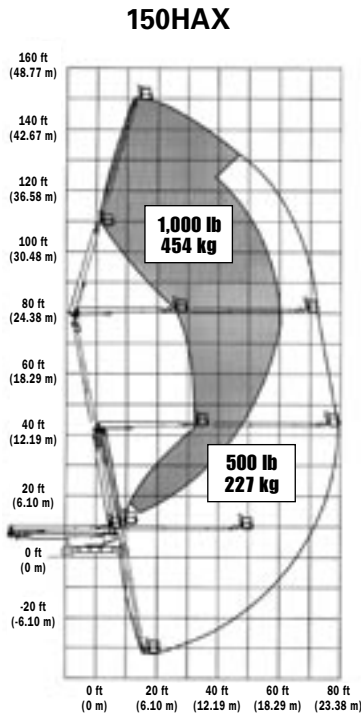

### Specifications

#### Reach

Platform Height	150 ft (45.72 m)
Horizontal Outreach	79 ft 3 in. (24.16 m)
Up and Over Height	79 ft 11 in. (24.36 m)
Below Ground Reach	30 ft 4 in. (9.25 m)
Swing	360° Continuous
Platform Capacity—Restricted	1,000 lb (454 kg)
Platform Capacity—Unrestricted	500 lb (227 kg)
Platform Rotator	165° Hydraulic Jib
(Range of Articulation)	6 ft (1.83 m)
	132 degrees (+71, -61)

#### Dimensions

A. Platform Size	36 x 96 in. (0.91 x 2.44 m)
B. Overall Width—Axles Retracted	11 ft 6 in. (3.51 m)
C. Overall Width—Axles Extended	18 ft (5.49 m)
D. Tailswing (Stowed)	17 ft 7 in. (5.36 m)
Tailswing (Fully Elevated)	Zero
E. Stowed Height	14 ft (4.27 m)
F. Stowed Height (Platform Tilted)	10 ft 6 in. (3.2 m)
G. Stowed Length	39 ft 5 in. (12.01 m)
H. Stowed Length (Platform Tilted)	41 ft 7 in. (12.67 m)
I. Wheelbase	18 ft (5.49 m)
J. Ground Clearance	11 in. (28 cm)
Weight*	58,100 lb (26,354 kg)
Max. Ground Bearing Pressure**	120 psi (8.4 kg/cm <sup>2</sup> )

#### Chassis

Drive Speed	3 mph (4.8 kmph)
Gradeability	31%
Turning Radius (Inside)	
Axles Retracted	14 ft 10 in. (4.52 m)
Axles Extended	14 ft 7 in. (4.45 m)
Turning Radius (Outside)	
Axles Retracted	27 ft (8.23 m)
Axles Extended	30 ft 1 in. (9.17 m)
Tire Type/Size	445/65R22.5 Foam-Filled

#### Power Source

Diesel Engine	Cummins 4B3.9C 76 hp (57 kW)
Fuel Tank Capacity	68 gal. (257.41 L)
Hydraulic Reservoir	124 gal. (469.39 L)
Main Pump	3 Section Gear
Brakes	Spring Applied Hydraulic Release

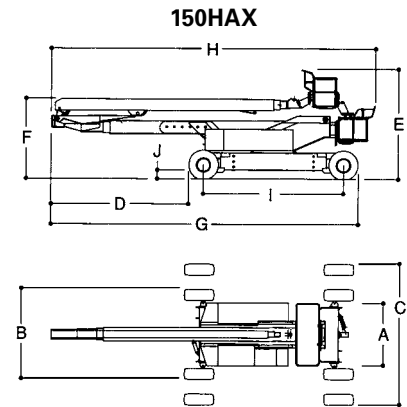

### The JLG "1 & 5" Warranty

JLG Industries, Inc. backs our products with our exclusive "1 & 5" Warranty. We provide coverage for one (1) full year, and cover all specified major structural components for five (5) years. These machines meet or exceed applicable OSHA Regulations in 29 CFR 1910.67, 29 CFR 1926.453, ANSI A92.5-2006 and CSA standard B354.4-02 as originally manufactured for intended applications. We reserve the right to make price, specification, and/or equipment changes without prior notification.