

Specifications

MODEL		TZ™-50	
MEASUREMENTS		US	Metric
Working height*		55 ft 6 in	17.09 m
Platform height		49 ft 6 in	15.09 m
Entry height		1 ft 8 in	.51 m
Horizontal reach		29 ft 2 in	8.89 m
Clear outreach		23 ft 1 in	7.04 m
Up and over clearance		22 ft	6.71 m
A Platform length		2 ft 2.8 in	.68 m
B Platform width		3 ft 8 in	1.12 m
C Height - stowed		6 ft 10 in	2 m
D Length - stowed		23 ft 6 in	7.16 m
E Width - stowed		5 ft 6 in	1.68 m
F Ground clearance - center		10 in	.25 m
G Length - outrigger footprint		14 ft 4 in	4.37 m
H Width - outrigger footprint		14 ft 4 in	4.37 m

PRODUCTIVITY			
Lift capacity (ANSI, CSA) - standard		500 lbs	227 kg
Lift capacity (ANSI, CSA) - rotating platform		500 lbs	227 kg
Lift capacity (CE/AUS) - standard		440 lbs	200 kg
Lift capacity (CE/AUS) - rotating platform		440 lbs	200 kg
Jib boom		4 ft 1 in	1.25 m
Jib working range		135°	
Self leveling platform		2.5° standard	
Platform rotation option		160° hydraulic	
AC power to platform		standard	
Turntable rotation		359° non-continuous	
Outrigger leveling capability		10°	
Drive speed		0.85 mph	1.37 km/h
Gradeability**		20%	
Towing speed rate		60 mph	97 km/h
Tongue weight - ANSI, CSA		400 lbs	181 kg
Tongue weight - CE		220 lbs	100 kg
Surge and parking brakes		standard	
Controls		variable speed system	
Tires - ANSI, CSA		ST 225/75 R15	
Tires - CE		215 R14C	
Coupler		2 in (5.08 cm) hitch coupler standard	

POWER			
Power source - standard		24V DC (four 6V 225 Ah batteries)	
Power source - drive option		24V DC (four 6V 244 Ah batteries)	
Power source - option		Hybrid DC/Gas Honda 5.5 hp (4.1 kW)	
Fuel tank capacity		.95 gal	3.6 L
Hydraulic tank capacity		4.75 gal	18 L
Hydraulic system capacity		8.0 gal	30 L

WEIGHT***			
ANSI, CSA, Australia		4,400 lbs	1,996 kg
CE		4,464 lbs	2,025 kg

STANDARDS COMPLIANCE ANSI A92.2, CSA C225, EN 280, AS 1418.10

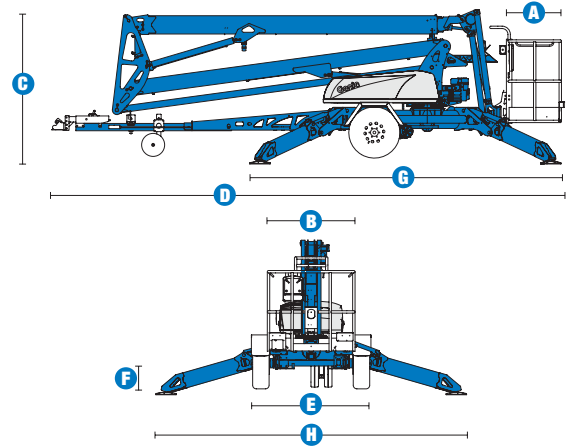

RANGE OF MOTION TZ™-50

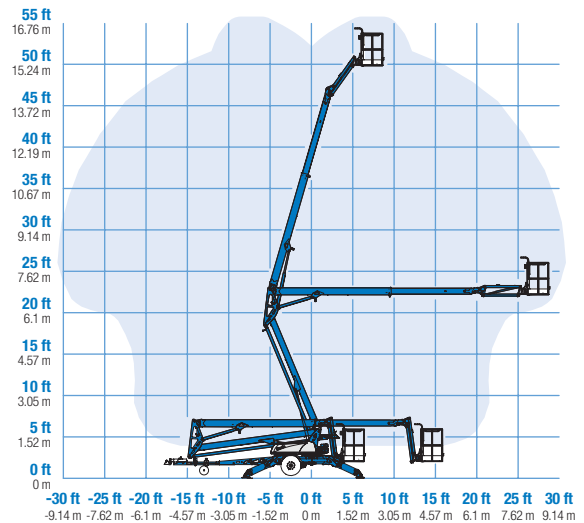

* The metric equivalent of working height adds 2 m to platform height. U.S. adds 6 ft to platform height.

** Gradeability applies to driving on slopes. See operator's manual for details regarding slope ratings.

*** Weight will vary depending on options and/or country standards.

Features

EASILY CONFIGURED TO MEET YOUR NEEDS

PLATFORM OPTIONS

- Aluminum 26.8 x 44 in (.68 x 1.12 m)
- 160° hydraulic platform rotation

POWER OPTIONS

- 24V DC power source
- Hybrid Honda 5.5 Hp (4.1 Kw) 45 amp charging system

DRIVE

- Drive and set option (ANSI, CSA, AUS)
- Drive only (CE)

COUPLER OPTIONS

Combination hitch

- 2 in (5.08 cm) ball coupler
- 2.31 in (5.87 cm) ball coupler
- 2.5 in (6.53 cm) I.D. pintle ring coupler
- Clevis coupler

TIRE OPTIONS

- ST 225/75 R15 tires (ANSI, CSA)
- 215 R14C tires (CE)

STANDARD FEATURES

MEASUREMENTS

- 55 ft 6 in (17.09 m) working height
- 29 ft 2 in (8.89 m) horizontal reach
- Up to 500 lb (227 kg) lift capacity

PRODUCTIVITY

- Industry leading working envelope
- Extension boom
- Self-leveling platform
- 4 ft jib with 135° working range
- AC wiring to platform
- Hydraulic outriggers
- Automatic 10° leveling system
- Outrigger interlocks
- Mechanical parking brake
- Hydraulic surge brakes
- Auxiliary pump down
- Combination hitch with coupler lever lock
- Dual jockey wheels
- 359° non-continuous turntable rotation
- Easy to access batteries
- Hour meter
- Tilt alarm / sensor
- Illuminated outrigger indicators

POWER

- 24V DC power source (four 6V 225 Ah batteries)



OPTIONS & ACCESSORIES

PRODUCTIVITY

- 160° hydraulic platform rotation
- Drive and set option with larger 244 Ah batteries pack
- 2 in (5.08 cm) ball coupler
- 2.31 in (5.87 cm) ball coupler
- 2.5 in (6.35 cm) I.D. pintle ring coupler
- Combination hitch
- Clevis coupler
- Wheel chocks
- Fluorescent tube caddy
- Full size spare tire
- Operational warning beacon package
- Non-marking outrigger footpads
- Battery charge indicator (BCI)
- Tool tray
- Bicycle guard (CE only)

POWER

- Hybrid Honda 5.5 Hp (4.1 Kw) 45 amp charging system option

Head Office
Westside, London Road,
Hickstead, West Sussex,
RH17 5LZ

T 01444 88 11 88
F 01444 88 11 99
E hiredesk@facelift.co.uk
W facelift.co.uk

facelift
access and safety made easy