

UpRight
TL33/38/49

trailer mounted boom lifts

Working heights to 17 m

Working Outreach to 8.3 m

Two person platform -
up to 215 kg capacity

Fast set-up time with
manual Quickset™ or
hydraulic outriggers

Compact travel dimensions
make towing easy

Optional drive-assist (TL49)
gives greater manoeuvrability



specifications	TL33	TL38	TL49
Working height	12.3 m	13.5 m	17.0 m
Platform height	10.3 m	11.5 m	15.0 m
Max. working height at full outreach -	8.46 m	8.15 m	9.3 m
Horizontal outreach	5.0 m	5.6 m	7.8 m
Jib length	1.33 m	1.2 m	n/a
Platform capacity	215 kg	215 kg	215 kg
Platform size (inside guardrails)	0.6 m x 1.2 m	0.6 m x 1.2 m	0.6 m x 1.2 m
Rotation (non-continuous)	370 degrees	370 degrees	370 degrees
Max. number of occupants	2	2	2
Travel dimensions			
Width A	1.52 m	1.52 m	1.60 m
Length B	5.5 m	5.97 m	5.97 m
Height C	1.99 m	1.99 m	1.99 m
Manual outriggers	Quickset™ with screw jack level adjusters. Electric interlocks prevent boom operation until all outriggers are taking load.		n/a
Hydraulic outriggers	Hydraulically-operated with check lock valves and interlock system, preventing operation until all outriggers are taking load.		
Outrigger footprint	3 m	3.3 m	3.98 m
Power source	24V DC, 4 x 6V 220 Ah Batteries		
Control system	One-hand proportional operating energy efficient motor control system.		
Tyres	185R13C 6 ply radials 195R14 tyres		
Braking	Automatic reverse and overrun brakes plus handbrake		
Weight with Hydraulic outriggers	n/a	1,490 kg	1,900 kg
Weight with Manual outriggers	1,240 kg	1,470 kg	n/a

Specifications subject to change without notice. Photos and diagrams in this brochure are for promotional purposes only. Refer to appropriate UpRight Operator's manual for detailed instructions on the proper use and maintenance of this equipment.

standard features

- Proportional one-hand controller
- Large platform
- Fully automatic on-board charger
- 24V DC motor and 220 Ah batteries
- Hydraulic (TL49) or **Quickset™** manual (TL38) outriggers
- Outrigger interlocks and warning alarm
- Energy-efficient motor control system
- Tilt alarm (Hydraulic Outriggers)
- Line contactor system for AC operation
- Outrigger safety interlocks and warning lights
- Cycle guards
- 5 year structural warranty

options

- Power line to platform
- Hour meter
- Flashing beacon
- Fibreglass platform
- Spare tire kit
- Drive assist (TL49)
- Generator pack
- Hydraulic or manual outriggers (TL38)

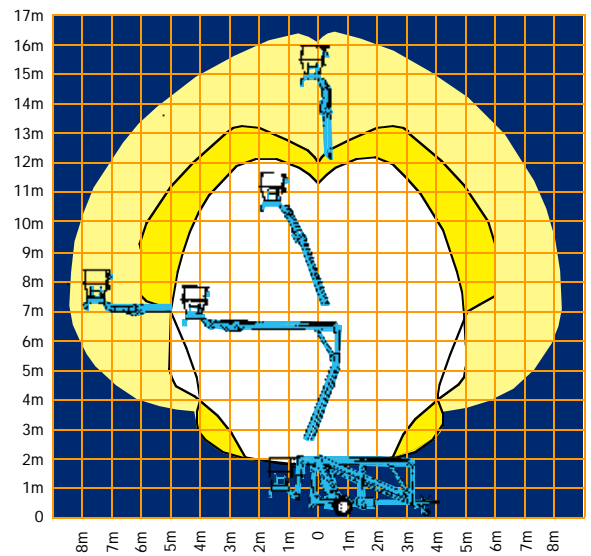

□ TL33 ■ TL38 □ TL49

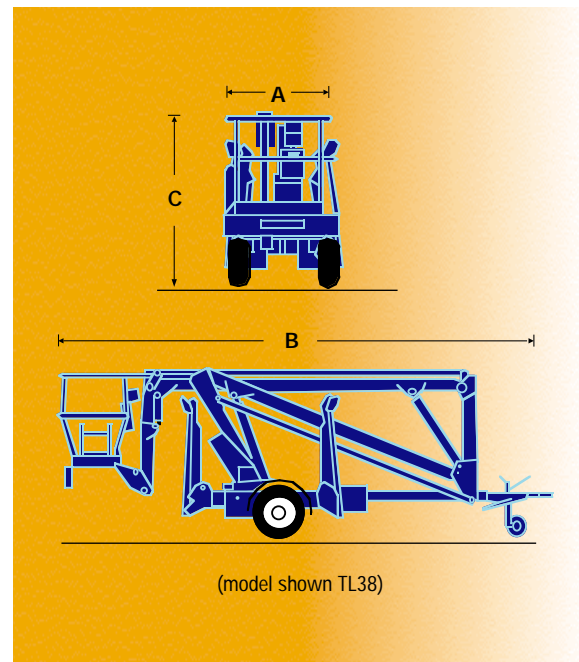

manufactured by

UpRight

Meets or exceeds applicable requirements of OSHA and ANSI A92.2 - 1999.



This product is available with the CE mark confirming compliance with all relevant European Machinery Directives